

TEMPLECITY INSTITUTE OF TECHNOLOGY AND ENGINEERING

Department of Electrical Engineering

Subject- Electrical Drives

Module-1

Answer any Six questions including Q.No.1 which is compulsory.

1. Answer all the following questions. [2×10]
 - (a) Write four advantage of an electric drive system.
 - (b) Draw the typical torque-speed characteristics of mechanical loads.
 - (c) What is a Group Electric Drive (Shaft Drive)?
 - (d) What is meant by “load equalization”?
 - (e) Why stator voltage control is more suitable for speed control of induction motor in fan type load than constant type load ?
 - (f) A train driven by separately excited dc motors has better co-efficient of adhesion than driven by series motor. Justify the statement.
 - (g) Compare static Kramer and Scherbius drive system.
 - (h) Draw the simplified speed/time curve for the main line services and show all necessary periods.
 - (i) What is self control of synchronous motor ?
 - (j) A 440 V, 60 Hz induction motor is to be used on a 50 Hz supply. What voltage should be used?

2. a) Why flywheel is mounted on the shaft of the motor in non-reversible drive? Deduce the expression for the Moment of Inertia of the flywheel. [4]
b) A motor has a heating time constant of 45 minutes and cooling time constant of 75 minutes. The motor has final steady state temperature rise of 50°C while delivering its continuous rating of 25 kW
 - i) Determine the load the motor can deliver for 15 minutes so that the temperature rise does not exceed 50°C .
 - ii) The motor delivers 35 kW for a period of 15 minutes followed by a shutdown for 15 minutes. Determine the maximum temperature rise. [6]

3. a) Why braking is required ? Explain each of the electrical braking briefly.
b) A 220 V, 1500 rpm, 11.6 A separately excited motor is controlled by a 1-phase fully-controlled rectifier with an ac source voltage of 230 V, 50 Hz. Enough filter inductance is added to ensure continuous conduction for any torque greater than 25 percent of rated torque, $R_a = 2$ ohm
 - i) What should be the value of the firing angle to get the rated torque at 1000 rpm?
 - ii) Calculate the firing angle for the rated braking torque and - 1500 rpm.
 - iii) Calculate the motor speed at the rated torque and $\alpha = 160^{\circ}$ for the regenerative braking in the second quadrant. [4+6]

4. a) Explain with sketch how the rheostatic braking is done in D.C. shunt and series motors [4]

- b) The switching frequency of the chopper is 2 kHz. The source voltage is 80V and the duty ratio is 30%. The load resistance is 4 ohm. Assume that the inductance and capacitance are ideal and large enough to sustain the load current and load voltage with little ripple. Calculate
- i) On time and switching period
 - ii) Average voltage across the load
 - iii) Average current of the load [6]
5. a) Formulate the expression for the tractive effort during acceleration period of a locomotive train.
b) Explain the speed control of induction motor by stator voltage/hertz control method. [5+5]
6. a) The distance between two stations is 1.92kms. The scheduled speed and the duration of stops respectively are 40kmph and 20sec. Assume the quadrilateral approximation of the speed-time curve and the coasting and braking retardation as 0.16kmphs and 3.2kmphs respectively. Determine the acceleration if the speed at the end of the accelerating period is 60.8kmph. Find also the duration of the coasting period. [6]
- b) Sketch and explain the static Kramer's variable speed drive system [4]
7. a) How the operation of synchronous motor shifts from motoring to generative braking ?
b) Draw the speed-torque characteristics of a three phase induction motor in its 4-quadrant region. [5+5]
8. Write short notes on the following (Any two) [5x2]
- a) Steady state stability of an electric drive
 - b) Static Ward-Leonard Drive System
 - c) Speed control by D.C. Chopper

Module-2

Answer any Six questions including Q.No.1 which is compulsory.

1. Answer all the following questions.

[2×10]

- a) Differentiate between the active and passive load related to drive system.
 - b) Draw the torque-speed characteristics of a separately excited DC motor during dynamic braking.
 - c) Why regenerative braking is not possible in half controlled rectifier ?
 - d) What are methods to reduce the energy loss during starting of three phase induction motor ?
 - e) What is the limitation for static Kramer drive and how it will be improved ?
 - f) Differentiate between the CSI and VSI .
 - g) Why stator voltage control is more suitable for speed control of induction motor in fan type load than constant type load ? What is meant by "load equalization"?
 - h) What is function of pantograph in electric locomotive train A train driven by separately excited dc motors has better co-efficient of adhesion than driven by series motor. Justify the statement.
 - i) A train driven by separately excited dc motors has better co-efficient of adhesion than driven by series motor. Justify the statement. Draw the simplified speed/time curve for the main line services and show all necessary periods.
 - j) What are merits and demerits of microprocessor based drive system ?
2. a) Derive the thermal modelling for heating and cooling curve ?
- b) A motor has a heating time constant of 90 minutes. If the temperature rise of the motor is 100°C when it is continuously loaded with its rated load. Determine the temperature rise of the motor after 2 hour of its rated load. If the temperature after 2 hour reaches the maximum permissible temperature (final steady state temperature with rated load applied continuously) after it is overloaded, determine the permissible overloading ? Assume constant loss=0.5 of full load copper loss.
3. a) Draw the circuit diagram and briefly explain the dynamic braking of a three phase induction motor. [3]
- b) Plot and briefly explain the torque-speed characteristics of dc shunt motor during regenerative braking. [3]
- c) Explain the speed control of three phase induction motor by rotor injection method. [4]
4. a) Why braking is required ? Explain each of the electrical braking briefly. [4]

b) A 2200V, 50 Hz, three phase, 6 pole, Y-connected squirrel cage Induction motor has following parameters.

$$R_s = 0.075\Omega, R_r' = 0.12\Omega \quad X_s = X_r' = 0.5\Omega$$

The combined inertia of motor and load is $100 \text{ kg}\cdot\text{m}^2$. Calculate

i) The time taken and energy dissipated in the motor during starting.

ii) The time taken and energy dissipated in the motor when it is stopped by plugging. [6]

5.a) Formulate the expression for the tractive effort during acceleration period of a locomotive train.

b) Explain the speed control of induction motor by stator voltage/hertz control method. [5+5]

6.a) The distance between two stations is 1.92kms. The scheduled speed and the duration of stops respectively are 40kmph and 20sec. Assume the quadrilateral approximation of the speed-time curve and the coasting and braking retardation as 0.16kmphs and 3.2kmphs respectively. Determine the acceleration if the speed at the end of the accelerating period is 60.8kmph. Find also the duration of the coasting period.

b) Sketch and explain the static Kramer's variable speed drive system [6+4]

7. a) How the operation of synchronous motor shifts from motoring to generative braking ?

b) Draw the speed-torque characteristics of a three phase induction motor in its 4-quadrant region. [5+5]

8. Write short notes on the following (Any two)

[5x2]

a) Steady state stability of an electric drive

b) Static Ward-Leonard Drive System

c) Speed control by D.C. Chopper

Module-3

Answer any *Six* questions including Q.No.1 which is compulsory.

1. Answer all the following questions.

[2×10]

- a) State the advantages of the electric drive?
- b) How electric friction is necessary for drive ?
- c) Chopper control drive have more advantages over phase controlled drive. Justify.
- d) What are the advantages of V/f methods for speed control of induction motor ?
- e) For good adhesion, the motor speed-torque characteristics should have low speed regulation and for good load sharing of loads between motors, the torque-speed curve should have high regulation, Why ?
- f) Mention some of the drawback of conventional Ward-Leonard scheme over static Ward-Leonard scheme.
- g) What are the advantages of single phase, 25KV, 50 hz transmission line for locomotive train.
- h) Draw the speed-torque characteristics of a three phase induction motor in its 4-quadrant region.
- i) Why regenerative braking is not preferred for dc series motor ?
- j) Plot the torque-speed characteristics of dc shunt motor during dynamic braking.

2.a) Derive the formula for overloading factor, when a motor is subjected to i) short time duty
ii) intermittent periodic duty.

b) Derive the transfer function of an armature controlled dc motor and draw the closed loop block diagram. [5+5]

3. a) What are the various factors that influence the choice of electric drives ?

[4]

b) A 230V, 960 rpm and 200 amp separately excited dc motor has an armature resistance of 0.02 ohm. The motor is fed from a chopper which provides both motoring and braking operations. The source has a voltage of 230V. Assuming continuous conduction

- i) Calculate duty ratio of chopper for motoring operation at rated torque and 350 rpm.
- ii) Calculate duty ratio of chopper for braking operation at rated torque and 350rpm.
- iii) If the duty ratio of chopper is limited to 0.95 and the maximum permissible motor current is twice the rated, calculate maximum permissible motor speed and power fed to the source?

4.a) A 150 V, dc shunt motor drives a constant torque load at a speed of 1200 rpm. The armature and field resistances are 1 ohm and 150 ohm respectively. The motor draws a line current of 10 amp at the given load. Calculate i) the resistance that should be added to the armature circuit to

reduce the speed by 50%. ii) Assume the rotational losses to be 100W, Calculate the efficiency of the motor without and with the added resistance. [6]

b) Draw and explain the various torque-speed characteristics of three phase induction motor at below and above base frequency. [4]

5.a) A 2.8 kW, 400V, 50Hz, 4 pole, 1370rpm delta connected squirrel cage induction motor has following parameters referred to the stator.

$R_s = 2\Omega$ $R_r' = 5\Omega$ $X_s = X_r' = 5\Omega$ $X_m = 80\Omega$. Motor speed is controlled by stator voltage control. When driving a fan load it runs at rated speed at rated voltage. Calculate i) motor terminal voltage, current and torque at 1200 rpm ii) motor speed, current and for the terminal voltage of 300 V.

b) With neat diagram describe the static Kramer's method for slip recovery power for three-phase induction motor. What are the drawbacks seen. [5+5]

6. a) A train service consists of following uniform acceleration of 1kmphs for 2 minutes. Free running for 30 minutes. Coasting for 2 minutes at a deceleration of 0.1kmphs. Uniform braking at 1.2 kmphs to stop the train. Stopping time 5 minutes. Calculate i) Distance between the stations ii) The scheduled speed [6]

b) Describe the duty cycle of main line service of the traction drive. [4]

7. a) Draw and explain the phasor diagram of synchronous motor operating with constant load torque at different value of rotor excitation. [5]

b) Explain the speed control of three phase induction motor by rotor emf injection method.

8. Write short notes on the following (Any two) [5x2]

a) Load equalization

b) Tractive effort for train movement

c) Drive mechanism in textile mill

MODULE-1

INTRODUCTION TO DRIVE SYSTEMS

Drives: Systems employed for motion control are called drives. Motion control is required in industrial as well as domestic applications like transportation system, rolling mills, paper mills, textile mills, machine tools, fans, pumps, robots, washing machines etc. Motion control may be translational, rotational or combination of both. Generally, a drive system is basically has a mechanical load, a transmission system and a prime mover. The prime mover may be I.C. engine, steam engine, turbine or electric motors. However, electric motors are predominantly used employed as prime mover due to certain advantages.

Advantages of Electric Drives:

- Flexible control characteristics.
- Starting and braking is easy and simple
- Provides a wide range of torques over a wide range of speeds (both ac and dc motor)
- Availability of wide range of electric power
- Works to almost any type of environmental conditions
- No exhaust gases emitted
- Capable of operating in all 4 quadrants of torque –speed plane
- Can be started and accelerated at very short time

Choice of Electrical Drives:

The choice of an electrical drive depends on a number of factors. Some important factors are:

- Steady state operation requirements: (nature of speed-torque characteristics, speed regulation, speed range, efficiency, duty cycle, quadrants of operation, speed fluctuations, rating etc)
- Transient operation requirement(values of acceleration and deceleration, starting, braking, speed reversing)
- Requirement of sources:(types of source, its capacity, magnitude of voltage, power factor, harmonics etc)
- Capital and running cost, maintenance needs, life periods
- Space and weight restrictions
- Environment and location
- Reliability

Basic Elements of the Electric Drive Systems:

Functional Block of Electric Drive System

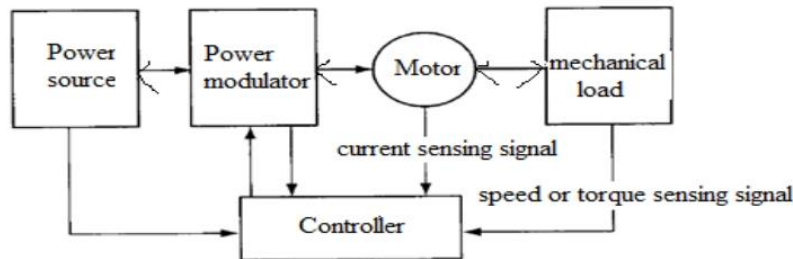

Fig 1.1

A modern electric drive system has five main functional blocks as shown above a mechanical load, a motor, a power modulator, a power source and a controller.

Power source: The power source provides the energy to the drive system. It may be dc or ac (single-phase or three-phase)

Power Converter: The converter interfaces the motor with the power source and provides the motor with adjustable voltage, current and frequency. During transient period such as starting, braking and speed reversal, it restricts source and motor current within permissible limits Also the converter converts the electric waveform into required signal that requires the motor.

Types of modulator:

- Controlled Rectifier(ac to dc)
- Inverter (dc to ac)
- AC Voltage Regulator (ac to ac)
- DC Chopper (dc to dc)
- Cyclo-converter (ac to ac) (Frequency converter)

Controller:

A well designed controller has several functions. The basic function is to monitor system variables, compare them with desired values, and then adjust the converter output until the system achieves a desired performance. This feature is used in speed and position control.

Electric motor: i) The basic criterion in selecting an electric motor for a given drive application is it meets power level and performance required by the load during steady state and dynamic operation.

ii) Environmental factors: In industry such as in food processing, chemical industries and aviation where the environment must be clean and free from arc. Induction motors are used instead of DC motor.

Mechanical Load:

The mechanical load usually called as machinery such as flow rates in pump, fans, robots, machine tools, trains and drills are coupled with motor shaft.

Classification of Load torque: Various load torques are broadly classified into two categories.

- A) Active Load Torque

B) Passive Load Torque

Load torques which have the potential to drive the motor under equilibrium conditions are called active load torques. Such load torques usually retain their sign when the direction of the drive rotation is changed. Torque due to the force of gravity, hoists, lifts or elevators and locomotive trains also torques due to tension, compression, and torsion undergone by an elastic body come under this category.

Components of the Load Torque (T_L) :

The load torque T_L can be further divided into the following components:

1. Friction torque T_F : The friction will be present at the motor shaft and also in the various parts of the load.
 2. Windage torque T_w : When a motor runs, the wind generates a torque opposing the motion. This is known as the windage torque.
 3. Torque required to do the useful mechanical work, T_M : The nature of this torque depends on the type of load. It may be constant and independent of speed, it may be some function of speed, it may be time invariant or time variant, and its nature may also vary with the change in the load's mode of operation.
- The friction torque ' T_F ' can be resolved into three components as shown in figure 1.2b.

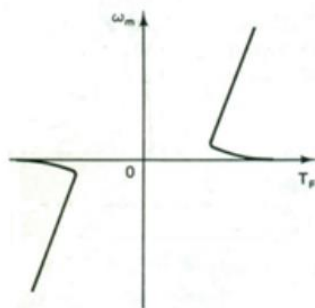

Fig 1.2 (a)

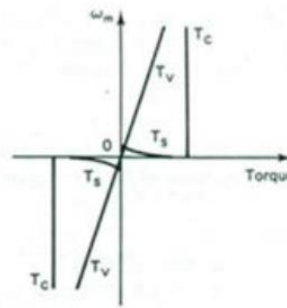

Fig 1.2 (b)

Friction torque and its components.

$$T_F = T_V + T_C + T_S \quad (1.1)$$

The first component T_V which varies linearly with speed is called viscous friction and is given by the following equation:

$$T_V = B\omega_m \quad (1.2)$$

where B is the viscous friction coefficient.

The windage torque T_w , which is proportional to speed squared, is given by the following equation:

$$T_w = C\omega_m^2 \quad (1.3)$$

where C is a constant.

So, $T_F = T_V$ is taken in account.

Now, the load torque can be represented by $T_L = T_M + T_V + T_w$

$$T_L = T_M + B\omega_m + C\omega_m^2 \quad (1.4)$$

In many applications $T_w = C\omega_m^2$ is very small compared to $B\omega_m$ and negligible compared to T_M . To simplify the analysis, the term T_w is neglected.

$$T_L = T_M + B\omega_w \quad (1.5)$$

Torque-Speed Characteristics of Mechanical Load:

Fundamental Torque Equations

Mechanical load exhibit wide variations of speed-torque characteristics. Load torques are generally speed dependent and can be represented by an empirical formula such as

$$T = CT_r \left(\frac{n}{n_r} \right)^k \quad (1.6)$$

Where C is a proportionally constant, T_r is the load torque at the rated speed n_r , n is the operating speed, and k is an exponential coefficient representing the torque dependency speed. Figure shows the typical mechanical loads.

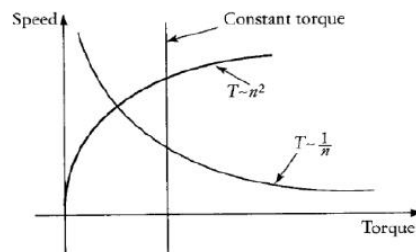

Typical speed-torque characteristics of mechanical loads

1. Torque independent of speed.

The characteristics of this type of mechanical load are represented by setting k is equal to zero and C equals to 1. While torque is independent of speed. Such examples are hoists, the pumping of water etc.

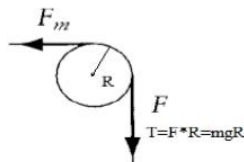

2. **Torque linearly dependent on speed.** The torque is linearly proportional to speed $k=1$, and the mechanical power is proportional to the square of the speed. An example would be a motor driving a dc generator connected to a fixed resistance load with constant field. It can be shown as

$$T = \frac{P}{\omega} \quad \text{where } P \text{ is the power generated by generator} \quad (1.7)$$

But $P=VI$ and $T = \frac{P}{\omega} = \frac{k^2 \omega^2}{R\omega} = \frac{k^2 \omega}{R}$ (1.8)

$\Rightarrow T \propto \omega$ (1.9)

3. Torque proportional to the square of speed.

The torque-speed characteristic is parabolic, $k=2$. Such examples of loads are fans, centrifugal pumps, and propellers.

$T \propto \omega^2$ (1.10)

4. Torque inversely proportional to speed.

In this case, $k=-1$. Examples are milling, boring machines, road vehicle and traction etc. $T \propto \frac{1}{\omega}$ (1.11)

Combined torque-speed characteristics of Motor-Load system:

Speed-torque characteristics of motor and mechanical load

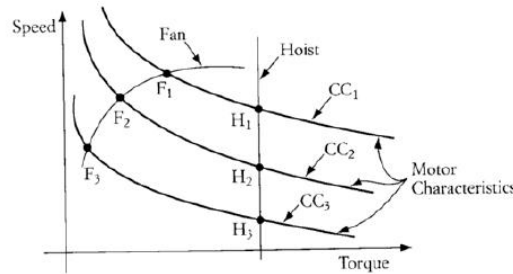

Dynamic of Motor-Load System:

Fundamental Torque Equations

The dynamic relations applicable to all types of motors and loads. The dynamic or transient condition. These condition appears during starting, braking and speed reversal of the drive.

A motor generally drives a load (machine) through some transmission system. While the motor always rotates, the load may rotate or may undergo a translational motion. It is convenient, however, to represent the motor load system by an equivalent rotational system, as shown in figure .

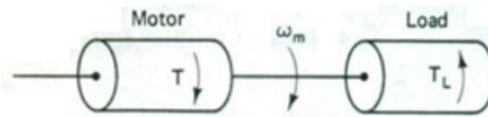

The following notations is adapted:

J = polar moment of inertia of the motor-load system referred to the motor shaft, $Kg\cdot m^2$

ω_m = instantaneous angular velocity of the motor shaft, rad/ sec

T_m = developed torque of the motor, N-m

T_L = the load (resisting) torque, referred to the motor shaft, N-m

Any motor-load system can be described by the following fundamental torque equation during dynamic condition:

$$T_m = T_L \pm \frac{d}{dt}(Jw_m) \quad (1.12)$$

$$\Rightarrow T_m = T_L \pm J \frac{dw_m}{dt} \pm w_m \frac{dJ}{dt} \quad (1.13)$$

This equation is applicable for variable inertia drives such as mines winder, industrial robots etc.

$$\text{And } T_m = T_L \pm J \frac{dw_m}{dt} \quad (1.14)$$

This equation is for constant inertia i.e. $\frac{dJ}{dt} = 0$

negative sign for deceleration and positive sign for acceleration.

Acceleration or deceleration depends on whether T_m is greater or less than T_L . During acceleration, motor should supply not only load torque T_L but also an additional torque component called inertia torque $J \frac{dw_m}{dt}$ to overcome the drive inertia. During deceleration, dynamic torque $J \frac{dw_m}{dt}$ has negative sign.

Therefore, it assists the motor torque T_m and maintains drive motion by extracting from stored kinetic energy.

The fundamental torque equation balance between the various torques in the drive may be considered while investing the dynamic behavior is

$$T_m = T_L + J \frac{dw_m}{dt} \quad (1.15)$$

$$\text{Where, } T_L = T_M + Bw_w \quad (1.16)$$

It is seen from the above equation that, when

$$T_m > T_L \quad \text{i.e.} \quad \frac{dw_m}{dt} > 0 \quad (1.17)$$

i)

the drive will be accelerating, in particular, picking up speed to reach rated speed

$$\text{ii) } T_m < T_L \quad \text{i.e.} \quad \frac{dw_m}{dt} < 0 \quad (1.18)$$

the drive will be decelerating and particularly, coming to rest

$$\text{iii) } T_m = T_L \quad \text{i.e.} \quad \frac{dw_m}{dt} = 0 \quad (1.19)$$

the motor will continue to run the same speed, if it were running or will continue to be at rest, if it were not running.

Stability:

Steady State Stability

A) Transient state Stability or Dynamic Stability

Criteria for Steady State Stability:

Let us assume that the motor-load speed-torque curve is at in equilibrium i.e. at steady state.

The disturbances changes the equilibrium states. The disturbances are two types. Such as

1. Due to slow change of inertia of rotating masses or that of inductances changes the equilibrium states slowly. So, effect of the inertia and the inductances are neglected for dynamics.

2. Due to large and sudden changes of inertia and inductances there is a sudden changes of equilibrium states. So, the inertia and inductances are taken for dynamic study.

Study of stability under conditions given above for the first type of disturbance relate to the field of steady state stability while for the second type of disturbance pertain to the field of dynamic or transient stability.

Let the equilibrium values of the torques and speed be denoted by T_m, T_L and w_m

Then at equilibrium, when deviation is not occurred

$$T_m = T_L \quad (1.20)$$

Let a small deviation in load torque is done, so that all equilibrium changes by $\Delta T_m, \Delta T_L$ and Δw_m

$$\text{then, the dynamics } T_m = T_L + J \frac{dw_m}{dt} \text{ becomes } T_m + \Delta T_m = T_L + \Delta T_L + J \frac{d(w_m + \Delta w_m)}{dt} \quad (1.21)$$

$$\Rightarrow \Delta T_m = \Delta T_L + J \frac{d\Delta w_m}{dt} \quad (1.22)$$

If we assume that these increments are so small that may be expressed as linear functions of the change in speed, then

$$\Delta T_m = \frac{dT_m}{dw_m} \Delta w_m \quad (1.23)$$

$$\Delta T_L = \frac{dT_L}{dw_m} \Delta w_m \quad (1.24)$$

Where $\frac{dT_m}{dw_m}$ and $\frac{dT_L}{dw_m}$ indicates derivatives at the point of equilibrium. Substituting these

relations in early equation and rearranging, we have

$$J \frac{d\Delta w_m}{dt} + \left(\frac{dT_L}{dw_m} - \frac{dT_m}{dw_m} \right) \Delta w_m = 0$$

$$\Delta w_m = (\Delta w_m)_0 e^{-\frac{t}{\tau}} \quad (1.25)$$

$$\tau = \frac{J}{\left(\frac{dT_L}{dw_m} - \frac{dT_m}{dw_m} \right)} \text{ called mechanical time constant.}$$

For the system to be stable when the exponent of the equation be negative. This exponent will be negative when

$$\frac{dT_L}{dw_m} - \frac{dT_m}{dw_m} > 0 \quad (1.26)$$

$$\text{or} \quad \frac{dT_L}{dw_m} > \frac{dT_m}{dw_m} \quad (1.27)$$

Transient state stability:

Concept of Transient Stability

Thus the equation of motion in terms of power, can be written as

$$P_m = P_{dyn} + P_L \quad (1.28)$$

Where P_m , P_{dyn} and P_L denote the motor power, dynamic power and the load power at the shaft respectively. The dynamic power is determined from the angular acceleration. Let the angular position of the shaft at any instant is taken as the δ between a point and reference which is rotating at synchronous speed. With sudden application of load, since the rotor slows down, the angular acceleration will be negative and hence the dynamic power will be given by

$$P_{dyn} = -P_j \frac{d^2\delta}{dt^2} \quad (1.29)$$

$$\text{Where, } P_j = J * \omega * \frac{2}{\text{Poles}} \quad (1.30)$$

The electromagnetic power P_m has two components (i) damping power which linearly varies with $\frac{d\delta}{dt}$ from synchronous speed and (ii) Synchronous power which is a function of load angle δ . Thus,

$$P_j \frac{d^2\delta}{dt^2} + P_d \frac{d\delta}{dt} + P(\delta) = P_L \quad (1.31)$$

Where, P_d is the damping power. Neglecting damping and assuming cylindrical rotor, then the above equation will be

$$P_j \frac{d^2\delta}{dt^2} + P_m \sin \delta = P_L \quad (1.32)$$

$$\text{Where, } P_m = \frac{VE}{X_s}$$

$$\text{Now, } \frac{d^2\delta}{dt^2} = \frac{P_L - P_m \sin \delta}{P_j} \quad (1.33)$$

Multiplying both sides by $\frac{d\delta}{dt}$, we have

$$\frac{d^2\delta}{dt^2} \left(\frac{d\delta}{dt} \right) = \left(\frac{P_L - P_m \sin \delta}{P_j} \right) \frac{d\delta}{dt}$$

$$\frac{d\delta}{dt} = \sqrt{\int_{\delta_0}^{\delta} \frac{2(P_L - P_m \sin \delta)}{P_j} d\delta} \quad (1.34)$$

Where δ_0 is the load angle before the disturbance, i.e., at time $t=0$. So, for the machine to be stable at the synchronous speed $\frac{d\delta}{dt} = 0$. Hence,

$$\sqrt{\int_{\delta_0}^{\delta} \frac{2(P_L - P_m \sin \delta)}{P_j} d\delta} = 0 \quad (1.35)$$

$$\int_{\delta_0}^{\delta} (P_L - P_m \sin \delta) d\delta = 0 \quad (1.36)$$

With the motor initial load P_{L1} , the operating point is at A corresponding to point δ_0 . As the load is suddenly increased to P_{L2} , the power angle swings to δ_f at which the speed is again synchronous. When

$$\text{the system is stable } \int_{\delta_0}^{\delta_i} (P_{L2} - P_m \sin \delta) d\delta + \int_{\delta_i}^{\delta_f} (P_{L2} - P_m \sin \delta) d\delta = 0 \quad (1.37)$$

where δ_i is the power angle corresponding to new load P_{L2} . So, from the equation it is to be written as

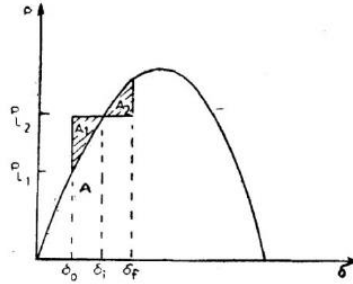

$$\int_{\delta_0}^{\delta_i} (P_{L2} - P_m \sin \delta) d\delta = \int_{\delta_i}^{\delta_f} (P_m \sin \delta - P_{L2}) d\delta \quad (1.38)$$

Or Area $A_1 = A_2$. This method of determining the transient stability of a drive system is called equal area criterion of stability.

Conclusion :

- i) If area $A_1 > A_2$, the drive is stable
- ii) If area $A_1 = A_2$, the drive is just stable
- iii) If $A_1 < A_2$, the motor loses synchronism

Rating of Motor:

From the classes of duty the motor rating is selected. A motor can be selected for a given class of duty based on its thermal rating with due consideration to pull out torque i.e. the overload must be within the pull out torque. The various classes of duties are

- Continuous duty

- Intermittent duty
- Short time duty

Continuous duty: Two classes of continuous duty are there. a) continuous duty at constant load b) continuous duty with variable load

- i) continuous duty at constant load: It denotes the motor operation at a constant load torque for a long duration enough to attain the steady state temperature. Ex. Paper mill drives, centrifugal pumps and fans etc. Frequent starting is not required. The rating of the machine is decided by input power.

If efficiency of the load and transmission is η , the input power to the load is

$$P = \frac{wT}{\eta} \quad (\text{for rotational body}) \quad (1.39)$$

T= load torque

$$P = \frac{F * V}{0.201 * \eta} \quad (\text{for linear motion}) \quad (1.40)$$

F= force exerted by load in kg

V= velocity of motion in m/sec

$$P = \frac{F * V}{2 * 0.102 * \eta} \quad (\text{for elevator}) \quad (1.41)$$

$$P = \frac{HQ\rho}{0.102 * \eta} \quad (\text{for pump}) \quad (1.42)$$

H= gross head comprising suction in mt

Q= quantity of delivery of pump in mt³/sec

ρ = density of liquid in kg/mt³

$$P = \frac{HQ}{0.102 * \eta} \quad (\text{for fan}) \quad (1.43)$$

Q=volume of air in mt³/sec

H= pressure of air in kg/mt²

- ii) continuous duty with variable load: Load has several steps in one cycle. The motor rating is neither selected for highest load nor lowest load rather the rating is selected on average losses for the load cycle. Ex. Metal cutting lathes, conveyors etc.

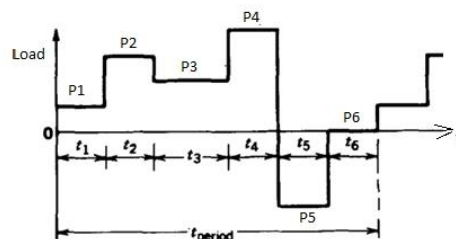

For variable motor mechanical load, the current to the motor is variable. To find the rating of the motor the equivalent current I_{eq} method is used for finding the motor rating.

Let each step of the load the power loss is composed of constant loss which is independent of load called core and variable loss called copper loss. The variable load consists of motor current I_1, I_2, \dots, I_6 for one cycle. Thus

$$P_c + I_{eq}^2 R = \frac{(P_c + I_1^2 R)t_1 + (P_c + I_2^2 R)t_2 + \dots + (P_c + I_6^2 R)t_6}{t_1 + t_2 + \dots + t_6}$$

$$I_{eq} = \sqrt{\frac{I_1^2 t_1 + I_2^2 t_2 + \dots + I_6^2 t_6}{t_1 + t_2 + t_3 + \dots + t_6}} \quad (1.44)$$

After I_{eq} is determined, a motor with next higher current rating ($= I_{rated}$) from commercially available ratings is selected.

DC motor: For the design of dc motor, the maximum allowable current is 2 times the rated current.

Induction and Synchronous motor: Here the maximum breakdown torque to rated is 2 to 2.25

Short Time Duty: In short time duty, the time of operation is less than the heating time constant and the motor is allowed to cool down to the ambient temperature before it is required to start again. If a motor rating of power P_r is subjected to short time duty load of KP_r , then the temperature rise will be far below than the permissible temperature θ_{per} . Therefore, the motor can be overloaded by a factor $K > 1$ such that, the maximum temperature rise just reaches the permissible value θ_{per} . Now, for the load KP_r , the time of operation is t_r .

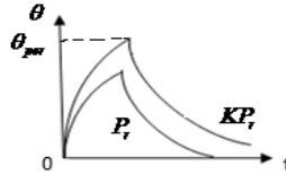

$$\theta_{per} = \theta_{ss} (1 - e^{-\frac{t_r}{\tau}}) \quad (1.45)$$

$$\frac{\theta_{ss}}{\theta_{per}} = \left(\frac{1}{1 - e^{-\frac{t_r}{\tau}}} \right)$$

For motor power P_r the loss is P_{lr}

For power KP_r , the loss is P_{ls} , then $\frac{\theta_{ss}}{\theta_{per}} = \frac{P_{ls}}{P_{lr}} = \left(\frac{1}{1 - e^{-\frac{t_r}{\tau}}} \right)$

But, $P_{lr} = P_c + P_{cu}$ and let $\alpha = \frac{P_c}{P_{cu}}$

$$\text{then, } P_{ls} = P_c + P_{cu} \left(\frac{KP_r}{P_r} \right)^2 = P_c + K^2 P_{cu} = P_{cu} (\alpha + K^2) \quad (1.46)$$

From the equations, the overloading factor $K = \sqrt{\frac{1+\alpha}{1-e^{-\frac{t_r}{\tau}}}} - \alpha$ (1.47)

Intermittent periodic duty: Here, the temperature neither reaches the steady state value during on nor reaches to ambient temperature during off period. So, the over-loading can be applied to the motor to bring to the steady state temperature for which the motor rating can be selected. The overloading factor can be found as

$$K = \sqrt{(\alpha + 1) \frac{1 - e^{-\left(\frac{t_r}{\tau_r} + \frac{t_c}{\tau_c}\right)}}{1 - e^{-\frac{t_r}{\tau_r}}} - \alpha} \quad (1.48)$$

Load Equalization:

In application such as electric hammer, pressing job, steel rolling mills etc, load fluctuates widely within short intervals of time. In such drives, to meet the required load the motor rating has to be high or the motor would draw the pulse current from the supply. Such pulse current from the supply gives voltage fluctuations which affects to the other load connected to it and affects to the stability of the source. The above problem can be met by using a flywheel connected to the motor shaft for non-reversible drives. This is called load equalization. The moment of inertia and the mechanical time constant can be found out from the load equalization problem.

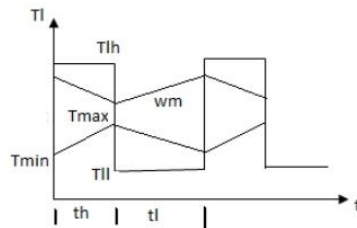

$$J = \frac{T_r}{\omega_{m0} - \omega_{mr}} \left(\frac{t_l}{\ln\left(\frac{T_{max} - T_{ll}}{T_{min} - T_{ll}}\right)} \right) \quad \text{or} \quad J = \frac{T_r}{\omega_{m0} - \omega_{mr}} \left(\frac{t_h}{\ln\left(\frac{T_{lh} - T_{min}}{T_{lh} - T_{max}}\right)} \right) \quad (1.49)$$

The mechanical time constant is

$$\tau_m = \left(\frac{t_h}{\ln\left(\frac{T_{lh} - T_{min}}{T_{lh} - T_{max}}\right)} \right) \quad (1.50)$$

The symbols used have their respective meaning.

Bidirectional Electrical Drives (1st and 2nd quadrant)

From the action-reaction theory of Newton’s Law, when an electric motor driving a mechanical load in a steady state operation, a force exerted by either part (motor or load) of drive system, is opposed by a force equal in magnitude and opposite in direction from the other. This can be understood by taking a bidirectional drives with **unidirectional speed and bidirectional load torque**.

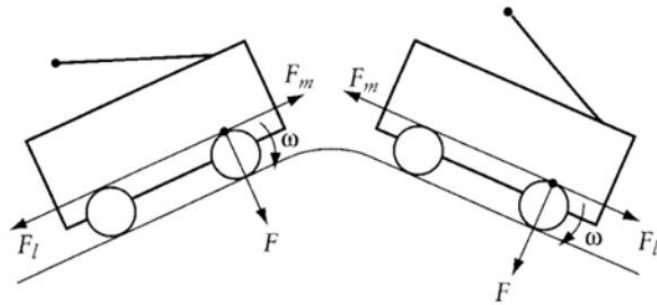

Bi-directional speed drive (1st and 4th quadrant)

In the figure shown below an elevator is moving passengers in both directions (up and down). For simplicity, let us assume that the elevator does not have a counterweight. In the upward directions, the motor sees the load force F_l which is a function of the weight of the passengers plus elevator cabin, cable etc. Since the weight and F_l are unidirectional, the motor force F_m is also unidirectional. The speed of the motor in this operation is bidirectional.

Bidirectional speed

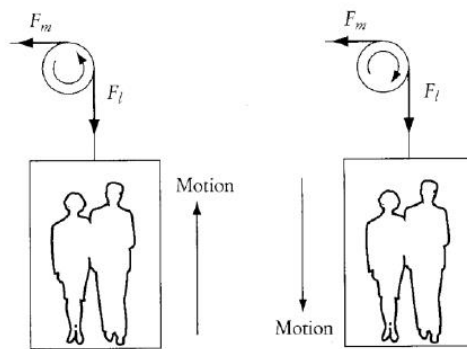

Four-Quadrant Drives

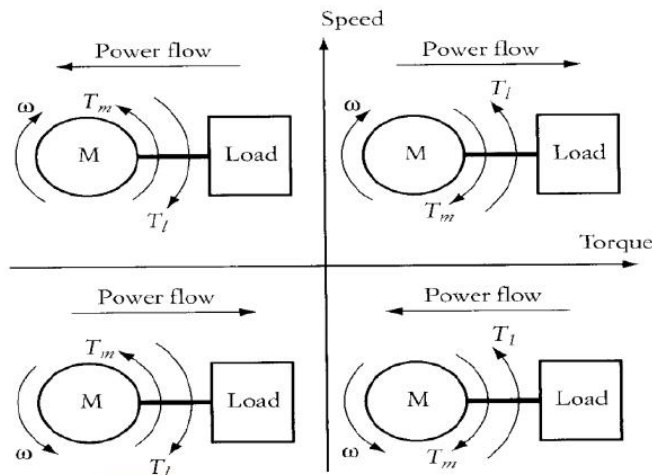

The Following conventions are to be followed.

1. When the torque of an electric machine is in the same direction as system speed, the machine consumes electric power from the source and deliver the mechanical power to the laod. The machine is then operating as a motor.
2. If the speed and the torque of the machine are in opposite directions, the machine is consuming mechanical power from the load and delivering electric power to the source. In this case, the machine is acting as generator.

Characteristics of Motor:

Three types of electric motors generally used for drive purposes. DC, Induction and Synchronous motor.

DC Drives:

Separately Excited Dc motor:

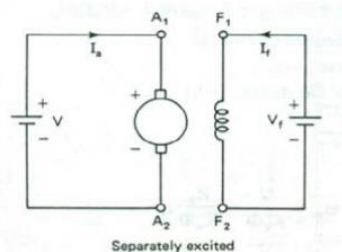

The basic equations for DC motor are

$$E = K_e \phi \omega_m \quad (1.51)$$

$$V = E + I_a R_a \quad (1.52)$$

$$T = K_e \phi I_a \quad (1.53)$$

Where, E = back emf in volt; ϕ = flux per pole in weber; V = supply voltage in volt; I_a = Armature current in Amp; R_a = Armature resistance in ohm; ω_m = speed of armature in rad/sec; T = torque developed in motor in N-mt

From the above set of steady state equations the steady state torque speed relation can be found out as

$$w_m = \frac{V}{K_e \phi} - \frac{I_a R_a}{K_e \phi} \quad (1.54)$$

$$w_m = \frac{V}{K_e \phi} - \frac{R_a T}{(K_e \phi)^2} \quad (1.55)$$

This equation can be applied to all series, shunt, compound and separately excited dc motors.

In the case of separately excited motors, if the field voltage is maintained constant, and assuming the flux as constant, then

$$K_e \phi = K \quad (\text{constant}) \quad (1.56)$$

The speed equation is written for the separately as well as shunt motor is

$$w_m = \frac{V}{K} - \frac{R_a T}{K^2} \quad (1.57)$$

The speed increases from the zero upto the base speed. This method is called the constant torque method. Beyond the rated voltage, and rated armature current the voltage can not be increased further due to insulation problem. So, to control the speed the flux control can be done. By decreasing the flux, speed can be increased above the base speed w_{m0} . This method is called constant power method where both voltage and armature current is kept constants. Further, in the below base speed region, the speed can be decreased from the no load speed w_{m0} by increasing the load. When the load increased, the speed decreased from its no load speed. This motor is used where the speed regulation is good.

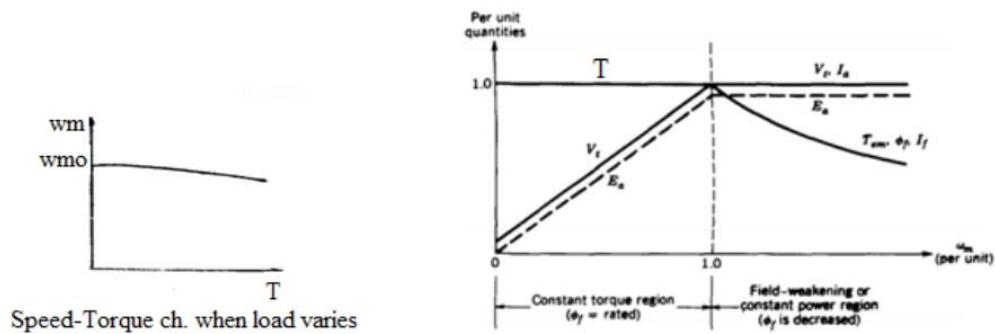

Dc Series Motor:

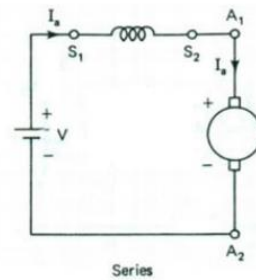

From the basic equation the speed can be written as

$$w_m = \frac{V}{K_e \phi} - \frac{R_a T}{(K_e \phi)^2}$$

In series motor, $T = K_e \phi I_a$, but $\phi \propto I_a$

$$\text{So, } T = K_e K_f I_a^2 \quad (1.58)$$

$$\omega_m = \frac{V}{\sqrt{K_e K_f}} \frac{1}{\sqrt{T}} - \frac{R_a}{K_e K_f} \quad (1.59)$$

In the case of series motor, any increase in torque is accompanied by an increase in the armature current and therefore, an increase in flux. Because the flux increases with torque, the speed must drop to maintain a balance between the induced voltage and the supply voltage. The characteristic is therefore, highly drooping.

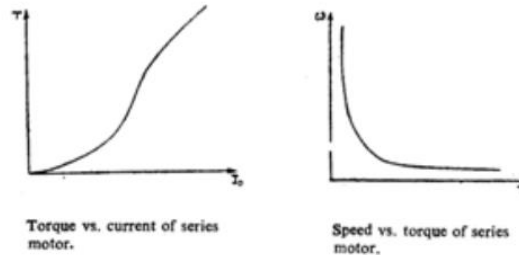

Methods of speed control

From the speed-torque relation from the equation it is seen that, the speed can be controlled by any one of the following three methods.

1. Armature voltage control
2. Armature resistance control (Rheostatic control)
3. Field flux control

Armature voltage control method: (DC shunt motor)

The speeds corresponding to two different armature voltages are V_1 and V_2 of a dc shunt motor are given by

$$\omega_{m1} = \frac{V_1}{K_e \phi} - \frac{R_a T}{(K_e \phi)^2} = \omega_{10} - \Delta \omega \quad (1.60)$$

$$\omega_{m2} = \frac{V_2}{K_e \phi} - \frac{R_a T}{(K_e \phi)^2} = \omega_{20} - \Delta \omega \quad (1.61)$$

The no load speed is directly proportional to the supply voltages. Keeping the load torque as constant, the family of motor torque-speed characteristics can be drawn for a given load torque.

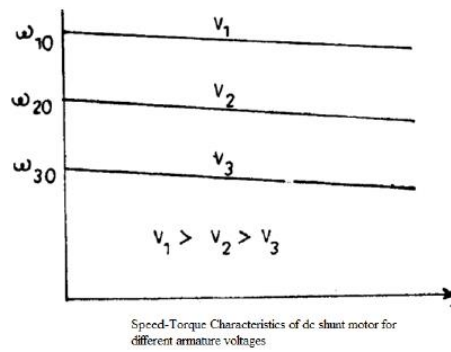

This method is only for below rated speed since the voltage magnitude should not be greater than the rated voltage. The variable voltages can be obtained by phase controlled rectifier and DC-DC Chopper converter.

DC Series motor:

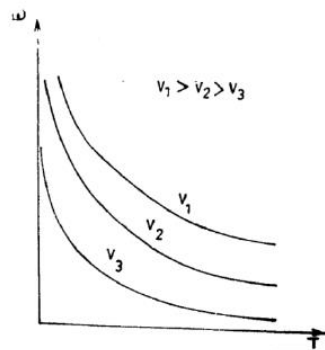

Field flux control method.

If the field of a separately or series excited motor running at a speed is weakened, its induced emf decreases. Because of low armature resistance, the current increases by an amount much larger than the decrease in the field flux. As a result, in spite of the weakened field, the torque is increased by a large amount, considerably exceeding the load torque. The surplus torque thus available causes the motor to accelerate and the back emf to rise. The motor will finally settle down to a new speed, higher than the previous one, at which the motor torque with the weakened field becomes equal to the load torque. Any attempt to weaken the field by a large amount will cause a dangerous inrush of current. Care should therefore be taken to weaken the field only slowly and gradually.

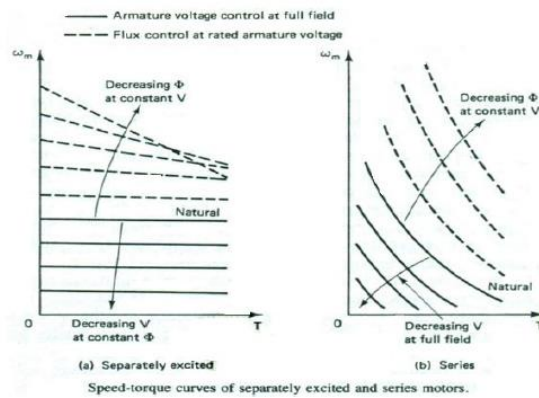

Armature resistance control:

Speed torque characteristics of separately excited (or shunt) and series motors for various values of external resistance R_e in series with the armature are shown.

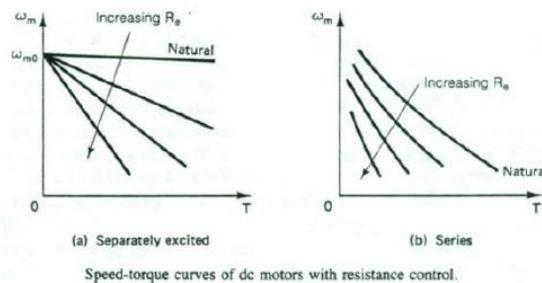

The main drawback of this method of speed control is its poor efficiency. Because of the poor efficiency, this method is seldom used with separately excited motors, except for getting speeds which are required for very short times.

Braking:

There are three methods of braking a dc motor

1. Regenerative braking.
2. Dynamic braking or rheostatic braking.
3. Plugging or reverse voltage braking

Regenerative Braking:

In regenerative braking, the energy generated is supplied to the source.

Separately Excited Motor:

The steady-state equivalent circuit of a separately excited motor and source is given in figure. If by some method the induced emf E is made greater than the source voltage V , the current will reverse. The machine will work as a generator and the source will act as a sink of energy, thus giving regenerative braking.

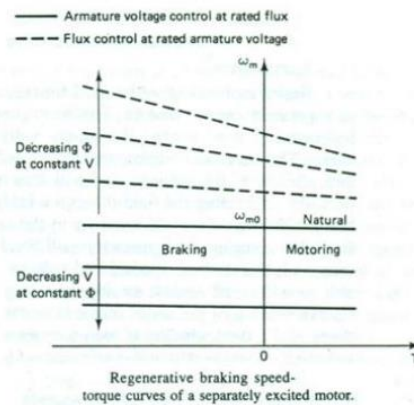

Series motor

Series motors cannot be used for regenerative braking in the same simple way as separately excited motors. For the regenerative braking to take place, the motor induced emf must exceed the supply voltage and the armature current should reverse. The reversal of armature current will reverse the current through the field, and, therefore, the induced emf will also reverse. The main advantage of regenerative braking is that the generated electrical energy is usefully employed instead of being wasted in rheostats as in the case of dynamic braking and plugging.

Dynamic Braking:

The dynamic braking of a dc motor is done by disconnecting it from the source and closing the armature circuit through a suitable resistance. The motor now works as a generator, producing the braking torque. For the braking operation, the separately excited (or shunt) motor can be connected either as a separately excited generator (fig.b), where the flux remains constant, or it can be connected as a self-excited shunt generator, with the field winding in parallel with the armature (fig.c).

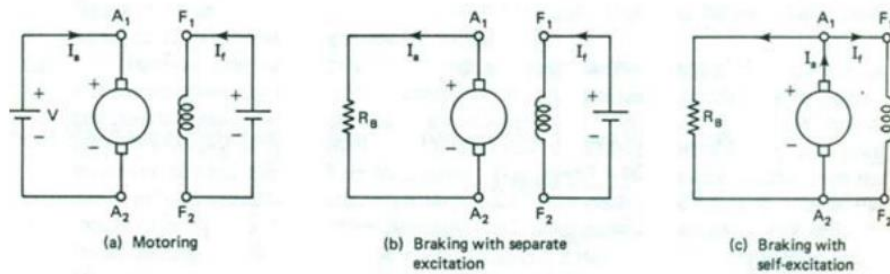

Dynamic braking of separately excited motor.

Series Motor:

For dynamic braking, the series motor is usually connected as a self-excited series generator. For the self-excitation, it is necessary that the current forced through the field winding by the induced emf aids the residual flux. This requirement is satisfied either by reversing the armature terminals or the field terminals.

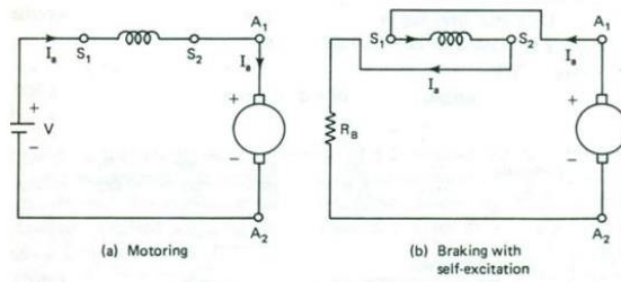

Dynamic braking of series motor.

Speed-Torque Characteristics during dynamic braking:

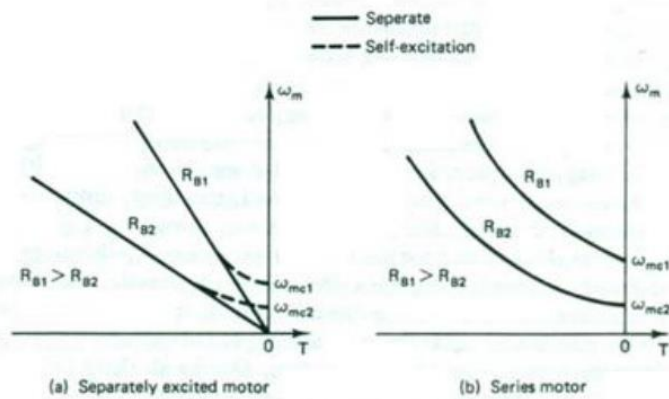

Speed-torque curves of dc motors under dynamic braking.

Plugging:

If the armature terminals (or supply polarity) of a separately excited (or shunt) motor when running are reversed, the supply voltage and the induced voltage will act in the same direction and the motor current will reverse, producing braking torque. This type of braking is called plugging. In the case of a series motor, either the armature terminals or field terminals should be reversed. Reversing of both gives only the normal motoring operation.

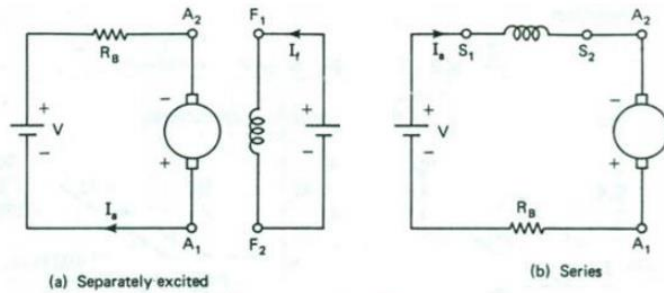

Plugging operation of dc motors.

Torque-speed characteristics:

When running at the rated speed, the induced voltage will be nearly equal to the supply voltage V . Therefore, at the initiation of braking, the total voltage in the armature circuit will be nearly $2V$. To limit the current within the safe value, a resistance equal to twice the starting resistance will be required.

Plugging is a highly inefficient method of braking. Not only is power supplied by the load, but also the power taken from the source is wasted in resistances.

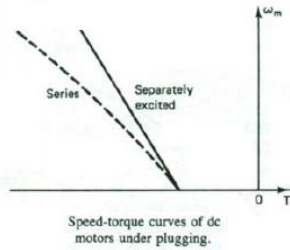

Starting:

Separately excited dc motor:

The maximum current that a de motor can safely carry during transients of short duration is limited by the maximum armature current that can be commutated without sparking. From the speed equation we see

$$\omega_m = \omega_0 - \Delta\omega$$

For large motors (greater than 10hp), the armature resistance R_a is very small. For these motors, the speed drop $\Delta\omega$ is very small, and the machine is considered to be constant speed machines. The torque developed at starting T_{st} and starting current I_{st} can be calculated by keeping speed as zero during starting.

$$\frac{V}{K\phi} = \frac{R_a I_{st}}{(K\phi)^2} \tag{1.62}$$

$$\Rightarrow T_{st} = (K\phi) \frac{V}{R_a} \tag{1.63}$$

The starting current is $I_{st} = \frac{V}{R_a} \tag{1.64}$

Effect of reducing source voltage during starting.

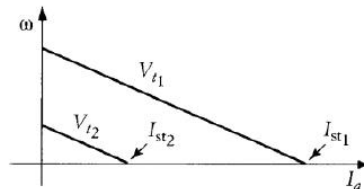

Effect of reducing external resistances.

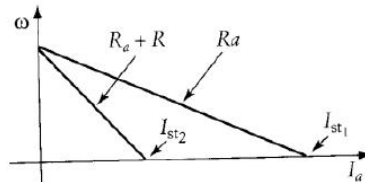

Series Motor:

In series motor, the starting current is less due to presence of field resistances in series with armature resistance.

$$I_{st} = \frac{V}{R_a + R_f} \tag{1.65}$$

$$T_{st} = KC \left(\frac{V}{R_a + R_f} \right)^2 \tag{series motor} \tag{1.66}$$

$$T_{st} = KC \left(\frac{V}{R_{fsh}} \right) \left(\frac{V}{R_a} \right) \tag{shunt motor} \tag{1.67}$$

From the two equations it is seen that,

T_{st} is less in shunt motor and more in series motor.

I_{st} is more in shunt motor and less in series motor. So, series motor is widely used in traction drive.

Induction motor:

Advantages

- Light in weight (cage type motor is usually used)
- Higher efficiency
- Low maintainance
- Robust and reliable
- Less cost than commutator type motor
- Ability to operate in dirty and explosive environment
- Advance feedback control technique such as field oriented control

Disadvantages

- Armature and field windings are highly coupled
- Non-linear modeling
- Multi-variable structure
- Controller such as power converter, inverter are relatively complex and expensive.

Steady-state performance of three phase induction motor:

The steady state performance can be studied from the power flow and equivalent circuit.

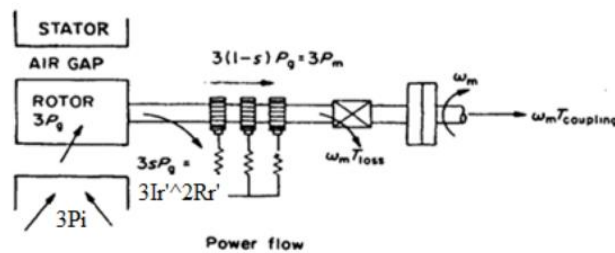

Input power to the stator is $P_i = 3V_s I_s \cos \theta_s$ (1.68)

Input power = stator cu loss+ core loss+ air gap power

$$\text{Stator cu loss } P_{scu} = 3(I_r')^2 R_s \quad (1.69)$$

$$\text{Core loss } P_c = 3 \frac{V_s^2}{R_m} \quad (1.70)$$

$$\text{The air gap power per phase } P_g = (I_r')^2 \frac{R_r'}{s} \quad (1.71)$$

$$\text{Rotor circuit power per phase } (I_r')^2 R_r' = s P_g \quad (1.72)$$

$$\text{Mechanical power } P_m = (1-s) P_g = (1-s) \frac{(I_r')^2 R_r'}{s} \quad (1.73)$$

$$\text{Thus electromagnetic torque is } T_m = \frac{P_m}{\omega_m} = \frac{P_g(1-s)}{\omega_s(1-s)} = \frac{P_g}{\omega_s} = \frac{1}{\omega_s} \frac{(I_r')^2 R_r'}{s} \quad (1.74)$$

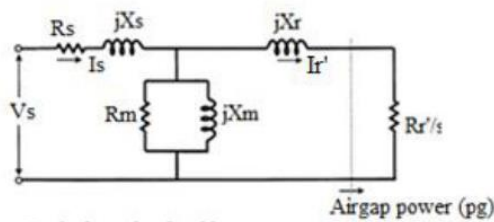

Equivalent circuit with respect to the stator
Per phase equivalent circuit of induction motor

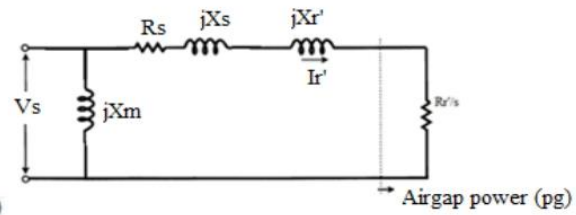

Approximate equivalent circuit
per phase equivalent circuit of induction motor

$$\text{But from equivalent circuit } I_r' = \frac{V_s}{\sqrt{\left(X_s + X_r'\right)^2 + \left(R_s + \frac{R_r'}{s}\right)^2}}$$

$$\text{Hence } T_m = \frac{1}{\omega_s} \frac{V_s^2}{\left(R_s + \frac{R_r'}{s}\right)^2 + \left(X_s + X_r'\right)^2} * \frac{R_r'}{s} \quad (1.75)$$

Steady-state torque-speed Characteristics:

When the slip is very small, $T_m \propto s$

When the slip is very large $T_m \propto \frac{1}{s}$

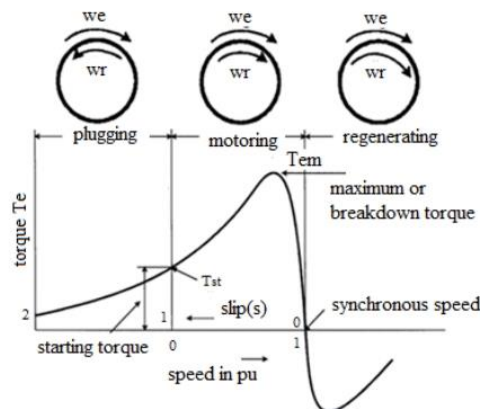

Three zones are there i) motoring zone ($0 < s < 1$) ii) regenerating zone ($s < 0$) iii) plugging zone ($1 < s < 2$)
 In the normal motoring zone $T_m = 0$ at $s = 0$. When slip increases, speed decreases but torque approaches maximum value. In the breakdown zone called quasi region, the stator drop is small and flux remains constant.

Features

- At $s = 0, T_m = 0$. Because there is no induced current and zero relative speed
- T_{em} is the maximum at s_m where $R_r' = sX_r'$
- T_{st} is starting torque when $s = 1$
- The motor is stable between (0 to s_m)

Four-quadrant operation of Induction motor :

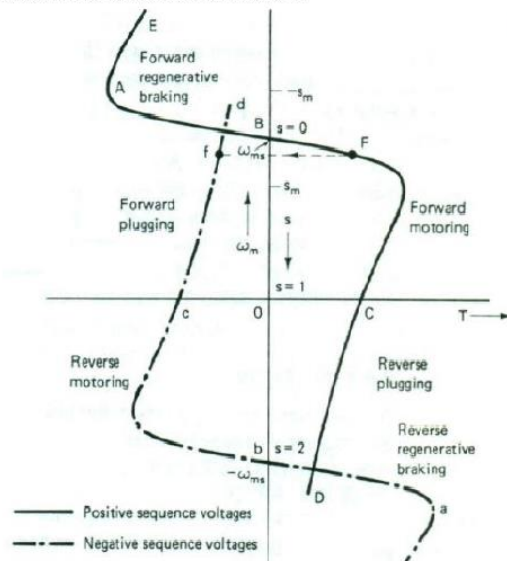

Speed-Control

There are five methods for speed control for modifying speed-torque characteristics. **i)** Stator voltage control **ii)** Stator Frequency control **iii)** Slip power recovery control ((Kramer drive)) or Rotor emf injection method **iv)** Rotor resistance control

Last two methods are only for slip ring induction motor.

Supply voltage control Method

$$T_m \propto V_s^2$$

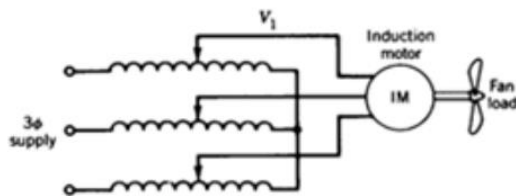

Auto-transformer voltage controller

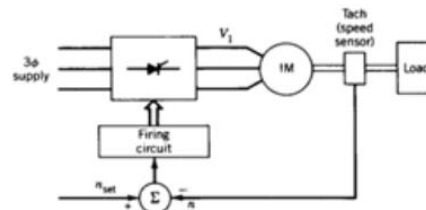

Closed loop operation

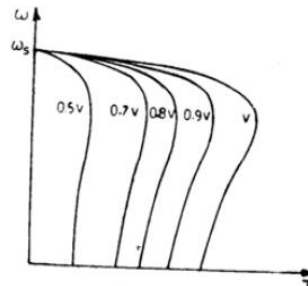

Speed-torque characteristics with voltage control

The curves indicate that the slip at maximum torque is independent of terminal voltages. The range of speeds within which steady state operation (for constant torque loads) may take place is the same for all voltages i.e. between the maximum torque and synchronous speed. Within that region there will be a small speed drop with decrease in voltage. This method is suitable for fan, pump and centrifugal drives.

Drawbacks:

- Gives poor energy efficiency at low speed
- This method is only suitable for below base speed

Stator Frequency control

By controlling the stator frequency 'f', synchronous speed which in turn determines the rotor speed of the motor. When the frequency is varied, then the magnetizing current I_m is also affected, which is given by

$$I_m = \frac{V_s}{X_m} = \frac{V_s}{2\pi f I_m} \quad (1.76)$$

But, the magnetizing current must be constant for constant breakdown torque (maximum torque). Therefore, for constant breakdown torque, $\frac{V_s}{f}$ ratio should be maintained constant. When the operating frequency is increased beyond the breakdown torque, then the torque gets reduced but the starting torque is increased. For further decrease in supply frequency $\frac{V_s}{f}$ can not be maintained constant. At very low frequency the apparent impedance increases that increased the voltage drop. Hence V_s decreased.

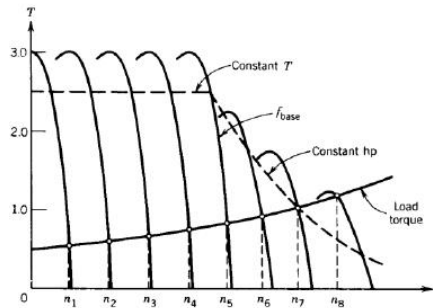
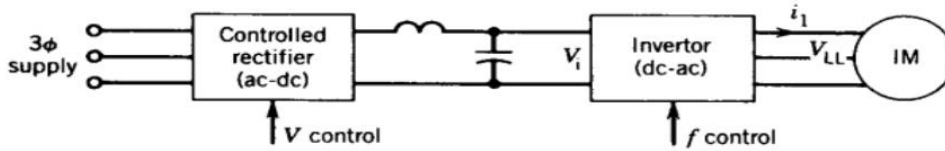

Slip power recovery control (rotor emf injection method):

In an induction motor, torque is equal to the power crossing the air gap divided by the synchronous mechanical speed. In early slip-ring induction motor drives, power was transferred through the motor to be dissipated in external resistances, connected to the slip-ring terminals of the rotor. This resulted in an inefficient drive over most of the speed range. More modern slip-ring drives use an inverter to recover the power called slip power from the rotor circuit, feeding it back to the supply system. One of the best recovery drive circuit is static Scherbius drive.

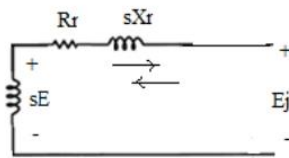

motor operation with injection voltage (Ej) in rotor

At running condition of slip with constant load, voltage and frequency the rotor current

$$I_r = \frac{sE}{\sqrt{(R_r^2 + (sX_r)^2)}} \quad \text{For slip to be very small, } R_r^2 \geq (sX_r)^2$$

$$I_r = \frac{sE}{R_r} \quad (1.77)$$

By giving additional voltage E_j at the rotor end, then $I_r = \frac{s_j E - E_j}{R_r}$, (1.78)

Since the load torque is constant, then

$$\begin{aligned} \frac{sE}{R_r} &= \frac{s_j E - E_j}{R_r} \\ \Rightarrow s_j &= s + \frac{E_j}{E} \end{aligned} \quad (1.79)$$

It is seen the slip increases when the injected emf is in phase opposition to the induced emf. Now, as the slip increases, the induced emf increases and hence the current till the developed torque is equal to the load torque. In this way the injected emf controls the speed. Similarly when the injected emf is in same phase then the slip decreases.

$$s_j = s - \frac{E_j}{E} \quad (1.80)$$

This slip in term of slip power in rotor circuit can be recovered and send back to ac supply by Scherbius drive and efficient thus increase.

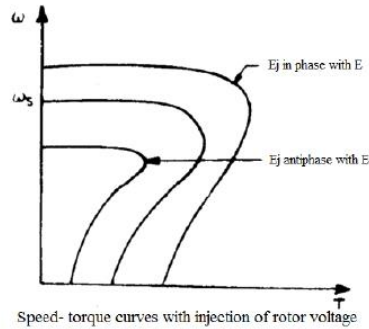

Scherbius method for slip power recovery

In this scheme, the rotor terminals are connected to a three-phase diode bridge that rectifies the rotor voltage. This rotor output is then inverted into mains frequency ac by a fully controlled thyristor converter operating off the same mains as the motor stator. The dc link current, smoothed by a reactor, may be regulated by controlling the firing angle of the converter in order to maintain the developed torque at the level required by the load. The current controller (CC) and speed controller (SC) are also indicated. The current controller output determines the converter firing angle α from the firing control circuit (FCC).

From the equivalent circuit and ignoring the stator impedance, the RMS voltage per phase in the rotor circuit is given by

$$V_R = \frac{V_s w_r}{n w_s} = \frac{V_s s w_s}{n w_s} = \frac{s V_s}{n} \quad (1.81)$$

Where ω_r and ω_s are the angular frequencies of rotor and stator voltages respectively. And 'n' is the ratio of the equivalent stator to rotor turns. The dc-link voltage at the rectifier terminals of the rotor, v_d is given by $v_d = \frac{3\sqrt{6}}{\pi} V_R$ (1.82)

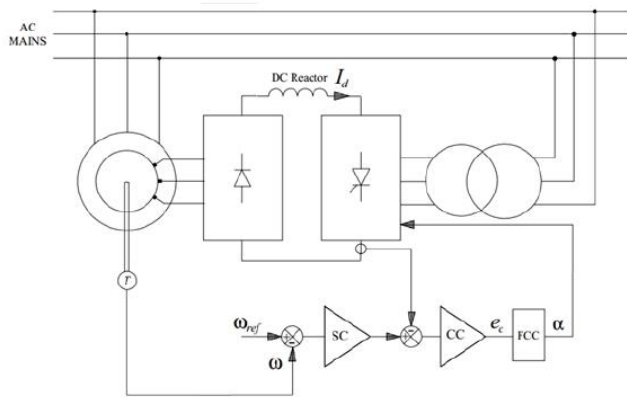

Static Scherbius scheme of slip power control

Assuming that the transformer interposed between the inverter output and the ac supply has the same turn ratio 'n' as the effective stator-to-rotor turns of the motor.

$$v_d = -\frac{3\sqrt{6}}{\pi} \frac{V_s}{n} \cos \alpha \quad (1.83)$$

The negative sign arises because the thyristor converter develops negative dc voltage in the inverter mode of operation. The dc-link inductor is mainly to ensure continuous current through the converter so that the expression (1.83) holds for all conditions of operation. Combining the preceding three equations gives

$$s\omega_s = -\omega_s \cos \alpha \quad \text{so that} \quad s = -n \cos \alpha \quad (1.84)$$

And the rotor speed is

$$\omega_0 = \frac{1}{P} (1-s)\omega_s = \frac{1}{P} \omega_s (1+n \cos \alpha) \quad \text{rad/sec} \quad (1.85)$$

Thus, the motor speed can be controlled by adjusting the firing angle α . By varying α between 180° and 90° , the speed of the motor can be varied from zero to full speed, respectively.

Rotor resistance control

The introduction of rotor resistance in slip ring induction motor will modify the speed-torque curves. The operating points from zero to synchronous speed can be obtained in this method.

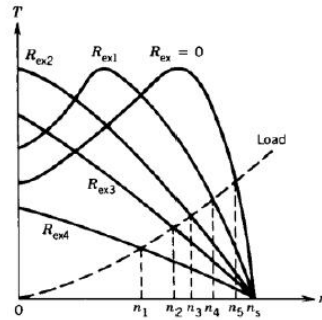
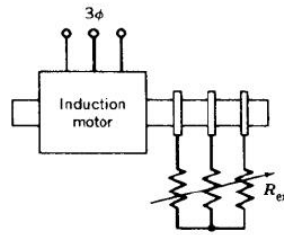

Braking:

Regenerative braking

The speed-torque curves obtained by the reversal of the phase sequence of the motor terminal voltages are also shown by dotted lines. With a positive sequence voltage across the motor terminals, the operation above synchronous speed gives the regenerative braking operation (portion BAE). Similarly, with a negative sequence voltage across the motor terminals, regenerative braking is obtained for speeds above the synchronous speed in the reverse direction (portion bae). In regenerative braking, the motor works as an induction generator, converting mechanical energy supplied by the load to electrical energy, which is fed to the source. Thus the generated energy is usefully employed.

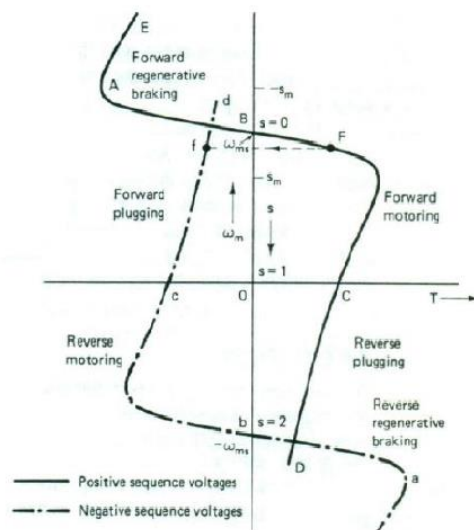

Plugging

An induction motor operates in the plugging mode for slips greater than 1. For positive sequence voltages, a slip greater than 1 is obtained when the rotor moves in the reverse direction (portion CD). Since the motor is running in the reverse direction, a positive torque provides the braking operation. With negative sequence voltages, plugging takes place on portion cd, shown by the chain-dotted line. When running in the forward direction, the motor can be braked by changing the phase sequence of the motor terminal voltages by simply interchanging the connections of any two motor terminals. This will transfer the operation from point F to f and braking will commence. The motor torque is not zero at zero speed. When braked for stopping, the motor should be disconnected from the supply at or near zero speed. An additional device will be required for detecting zero speed and disconnecting the motor from the supply. Therefore, plugging is not suitable for stopping. It is, however, quite suitable for reversing the motor. From the forward motoring (portion BC), the reverse plugging operation (portion CD) is obtained when an active load drives the motor in the reverse direction, as in crane and hoist applications. When operating this way, plugging is sometimes called counter-torque braking.

Dynamic braking

In dc dynamic braking, the motor is disconnected from the ac supply and connected to a dc supply. The flow of direct current through the stator windings sets up a stationary magnetic field. The relative speed between the stationary stator field and the moving rotor is now negative. Consequently, 3-phase voltages of reverse polarity and phase sequence (compared to the motoring in the same direction) are induced in the rotor. The resultant three-phase rotor currents produce a rotating field, moving at the rotor speed in the direction opposite to that of rotor, thus giving a stationary rotor field. Since both stator and rotor fields are stationary and rotor current flows in the reverse direction, a steady braking torque is produced at all speeds. It, however, becomes zero at standstill due to zero rotor currents.

Synchronous motor

In the synchronous motor, the stator windings are exactly the same as in the induction motor, so when connected to the 3-phase supply, a rotating magnetic field is produced. But instead of having a cylindrical rotor with a cage winding, the synchronous motor has a rotor with either a d.c. excited winding (supplied via slip rings), or permanent magnets, designed to cause the rotor to 'lock-on' or 'synchronise with' the rotating magnetic field produced by the stator. Once the rotor is synchronised, it will run at exactly the

same speed as the rotating field despite load variation, so under constant-frequency operation the speed will remain constant as long as the supply frequency is stable.

With the synchronous machine we again find that, the maximum (pull-out) torque which can be developed before the rotor is forced out of synchronism with the rotating field. This 'pull-out' torque will typically be 1.5 times the continuous rated torque, but for all torques below pull-out the steady running speed will be absolutely constant. The torque-speed curve is therefore simply a vertical line at the synchronous speed. We can see from Figure that the vertical line extends into quadrant 2, which indicates that if we try to force the speed above the synchronous speed the machine will act as a generator.

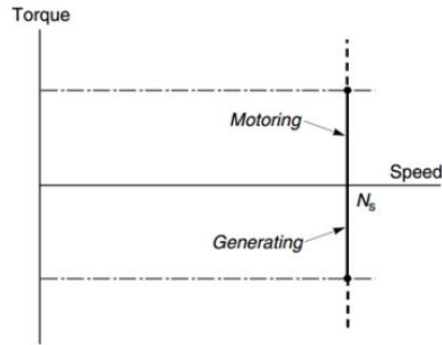

Steady state torque-speed characteristic for Synchronous motor at constant frequency

MODULE-2

CONTROL OF DRIVE SYSTEMS

Dc motors are widely used in many speed-control drives. Open-loop operation of dc motors may be satisfactory in many applications. When the load increases the speed of the motor drops and the new operating point of speed is obtained after the transient. For getting constant speed i.e. the initial operating point the open loop does not work. So, closed-loop control system is required. The basic block diagram of closed-loop control system is shown.

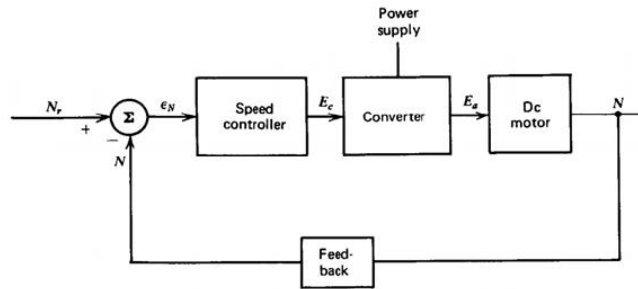

Basic block diagram of a closed-loop speed-control system.

If the motor speed decreases due to application of additional load torque, the speed error ϵ_N increases, which increases the control signal E_c . This in turn changes the firing angle of the converter, and thus increases the motor torque to restore the speed of the drive system. The system passes through a transient period until the developed torque matches the applied torque. A closed-loop system improves the dynamic response specially during acceleration, deceleration and disturbances such as loading in drive system. The response of a closed-loop system can be studied by using transfer function techniques.

Separately Excited DC motor Drives

Armature voltage control is inherently a closed loop control system in dc motor drives. However, the output speed signal can not be measured and the speed error is not found properly. This closed loop is further extended by using a feed back tachogenerator with speed controller and converter for modern control drives.

Motor Transfer function without tachogenerator and converter. (Armature voltage speed control)

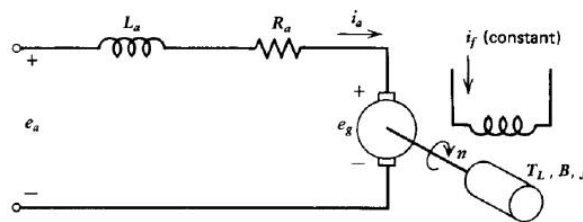

The basic set of equations are

$$e_a = i_a R_a + L_a \frac{di_a}{dt} + e_g \quad (2.1)$$

$$\text{Where } e_g = K_a n \quad (2.2)$$

The torque balance equation is $T_m = T_L + Bn + J \frac{dn}{dt}$ (2.3)

Also $T_m = K_a i_a$ (2.4)

In Laplace domain all time domain equations are brought into frequency domain

$$E_a(s) = I_a(s)R_a + L_a s I_a(s) + E_g(s) \quad (2.5)$$

$$E_g(s) = K_a N(s) \quad (2.6)$$

$$T_m(s) = T_L(s) + BN(s) + JsN(s) \quad (2.7)$$

$$T_m(s) = K_a I_a(s) \quad (2.8)$$

From the eq.(2.5)

$$I_a(s) = \frac{E_a(s) - E_g(s)}{R_a + sL_a} = \frac{[E_a(s) - E_g(s)] * 1/R_a}{1 + s\tau_a} \quad (2.9)$$

where $\tau_a = \frac{L_a}{R_a}$ electrical time constant

From eq.(2.7)

$$N(s) = \frac{T_m(s) - T_L(s)}{B + sJ} = \frac{[T_m(s) - T_L(s)] * 1/B}{1 + s\tau_m} \quad (2.10)$$

where $\tau_m = \frac{J}{B}$ mechanical time constant

The closed loop T.F. is

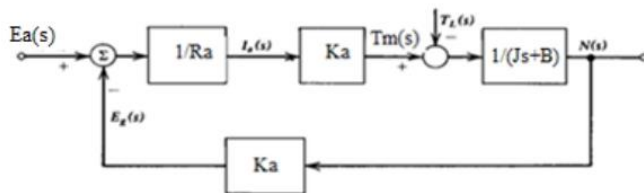

There are two inputs one electrical input voltage E_a and the other mechanical load torque T_L . So, considering one input at a time neglecting others the total T.F. is coming as $T_L = 0$ and neglecting L_a

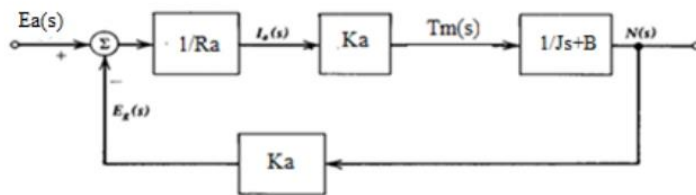

$$\frac{N(s)}{E_a(s)} = \frac{K_m}{1 + s\tau_m} \quad (2.11)$$

Where $K_m = \frac{(K_a / R_a)}{(B + K_a^2 / R_a)}$ motor gain constant and $\tau_m = \frac{J}{B + K_a^2 / R_a}$ mechanical time constant

K_a is called electric friction and $B + K_a^2 / R_a$ called total friction

Letting $E_a(s) = 0$

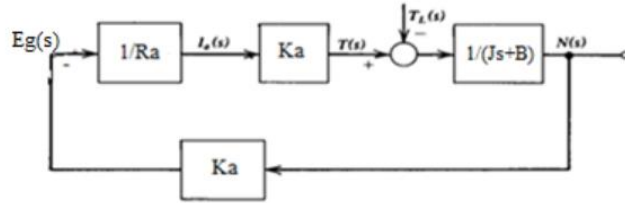

$$\frac{N(s)}{T_L(s)} = \frac{-K}{s\tau_m + 1} \quad (2.12)$$

where $K = \frac{1}{B + K_a^2 / R_a}$

Combining eq.(2.11 and 2.12)

$$N(s) = \frac{K_m}{s\tau_m + 1} E_a(s) - \frac{K}{s\tau_m + 1} T_L(s) \quad (2.13)$$

Neglecting electrical time constant the armature voltage control is said to be first order system.

For the simplicity the T.F. can be represented by neglecting the torque now $\frac{N(s)}{E_a(s)} = \frac{K_m}{s\tau_m + 1}$

Motor Transfer function with tachogenerator and converter. (Armature voltage speed control)

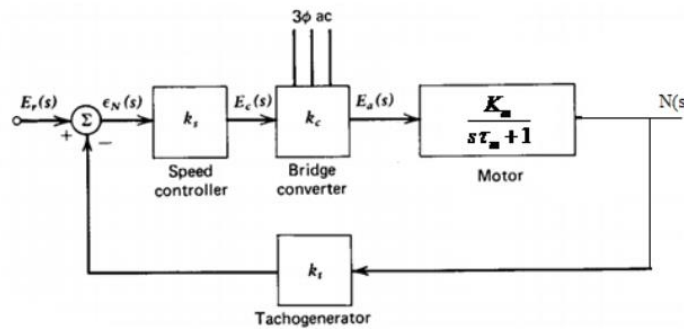

closed-loop speed control

$$\frac{E_a(s)}{E_c(s)} = K_c = \frac{3\sqrt{2}V_{LL}}{\pi\hat{E}_c} \quad (2.14)$$

Where \hat{E}_c corresponds to 0° firing angle and V_{LL} is the ac line to line rms value. The speed controller may be P or PI type can be taken.

Now, the closed loop T.F. can be formed sa

$$\frac{N(s)}{E_r(s)} = \frac{G(s)}{1 + G(s)H(s)} \quad (2.15)$$

$$\text{Where } G(s) = \frac{K_s K_c K_m}{1 + s \tau_{m1}} \quad (2.16)$$

$$H(s) = K_t \quad (2.17)$$

$$\text{From the eq (2.15), (2.16), (2.17)} \quad \frac{N(s)}{E_r(s)} = \frac{K_1}{1 + s \tau_1} \quad (2.18)$$

$$\text{Where } K_1 = \frac{K_s K_c K_m}{K_s K_c K_m K_t + 1} \quad \text{and} \quad \tau_1 = \frac{\tau_{m1}}{K_s K_c K_m K_t + 1}$$

Transfer function for field control method:

Some drives are operated with field control and with a constant current in the armature circuit. Usually, the armature current is maintained constant using a closed-loop system. Since the armature time constant is very small compared to the field time constant, the response time of the closed-loop system controlling the armature current can be considered zero, and thus the change in the armature current due to the variation of field current and motor speed can be neglected.

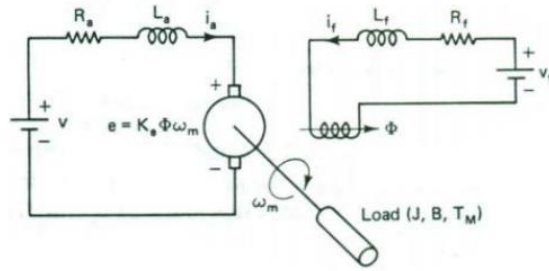

The dynamics for the field control are

$$V_f = i_f R_f + L_f \frac{di_f}{dt} \quad (2.19)$$

Assuming the armature current constant

$$T_m = K_a i_f \quad (2.20)$$

$$T_m = T_L + Bn + J \frac{dn}{dt} \quad (2.21)$$

$$\Rightarrow J \frac{dn}{dt} = T_m - T_L - Bn \Rightarrow J \frac{dn}{dt} = K_a i_f - T_L - Bn$$

Putting the Laplac transformation in those equations we get

$$V_f(s) = I_f(s)R_f + L_f s I_f(s) \Rightarrow I_f(s) = \frac{V_f(s)}{R_f(1 + s \tau_f)} \quad (2.22)$$

$$JsN(s) = K_a I_f(s) - T_L(s) - BN(s) \Rightarrow N(s) = \frac{K_a I_f(s) - T_L(s)}{Js + B}$$

Putting the value of $I_f(s)$ we have
$$N(s) = \frac{K_a V_f(s) - T_L(s)}{R_f(1 + s\tau_f)(Js + B)}$$

$$N(s) = \frac{V_f(s)(K_a / R_f B) - T_L(s)}{(1 + s\tau_f)(1 + s\tau_m)} \quad (2.23)$$

For field control system which is suitable for above base speed, the load torque is assumed to be

small. so,
$$N(s) = \frac{V_f(s)(K_a / R_f B)}{(1 + s\tau_f)(1 + s\tau_m)} = \frac{N(s)}{V_f(s)} = \frac{K_m}{(1 + s\tau_f)(1 + s\tau_m)} \quad (2.24)$$

Field control method is a second order system.

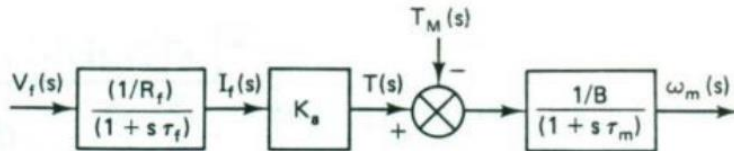

Block diagram of separately excited motor with field control.

Solid State Control

DC motor speed control by solid state can be done by two methods i) dc-dc Chopper control ii) Phasr rectifier control method

Chopper control of Dc motor drive: (separately excited)

This is one of the simplest power-electronic/machine circuits. With a battery, it is currently the most common electric road vehicle controller; the 'chopper' is also used for some d.c. rail traction applications. The principal difference between the thyristor-controlled rectifier and the chopper is that in the former the motor current always flows through the supply, whereas in the latter, the motor current only flows from the supply terminals for part of each cycle.

The chopper may use transistor,thyristor,MOSFET or IGBT as switches.

A single-switch chopper using a thyristor can supply positive voltage and current to a d.c. motor, and is therefore,restricted to quadrant 1 motoring operation. When regenerative and/or rapid speed reversal is called for, more complex circuitry is required,involving two or more power switches. When the motor voltage is less than the battery,the step down chopper is used and when the motor voltage is greater than the battery voltage, a 'step-up' chopper using an additional inductance as an intermediate energy store is used.

Function:

$$V_{dc} = V, CH1 \text{ on}$$

$$V_{dc} = 0, CH1 \text{ off}$$

$$D_1 \text{ on}$$

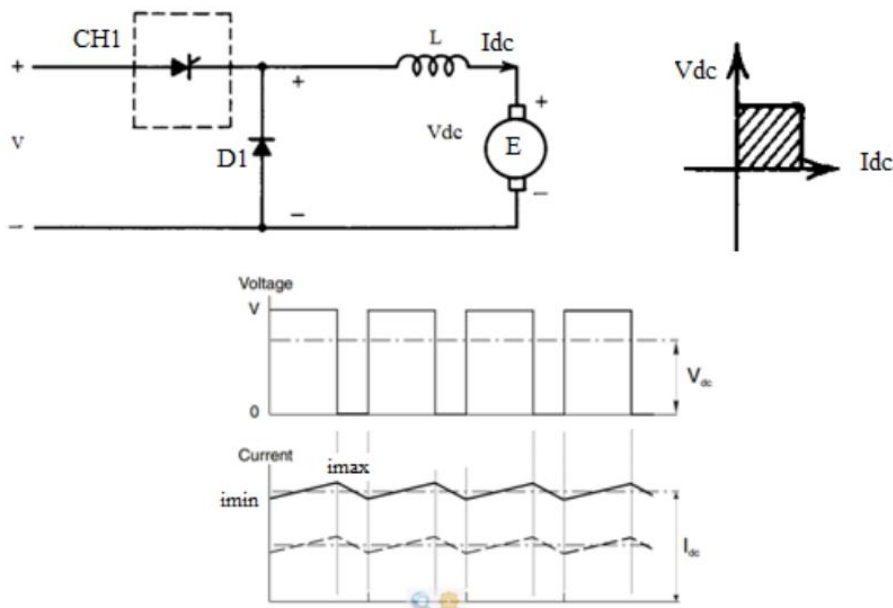

The shape of the armature voltage waveform reminds us that when the transistor is switched on, the battery voltage V is applied directly to the armature, and during this period the path of the armature current is indicated by the dotted line in Figure . For the remainder of the cycle the transistor is turned 'off' and the current freewheels through the diode, as shown by the dotted line in Figure. When the current is freewheeling through the diode, the armature voltage is clamped at (almost) zero.

The speed of the motor is determined by the average armature voltage, (V_{dc}), which in turn depends on the proportion of the total cycle time (T) for which the transistor is 'on'. If the on and off times are defined as $T_{on} = \delta T$ and $T_{off} = (1 - \delta)T$ where $0 < \delta < 1$, then the average voltage is simply given by

$$V_{dc} = \frac{1}{T} \int_0^{T_{on}} V dt$$

$$V_{dc} = \delta V \quad (2.25)$$

Where, $\delta = \frac{T_{on}}{T}$ duty ratio or time ratio and speed control is effected via the on time ratio, δ .

If we ignore resistance, the equation governing the current during the 'on' period is

$$V = E + L \frac{di}{dt} \quad \text{or} \quad \frac{di}{dt} = \frac{1}{L} (V - E) \quad (2.26)$$

During this 'on' period the battery is supplying power to the motor. So, the current rises.

During the 'off' period, the equation governing the current is

$$0 = E + L \frac{di}{dt} \quad \text{or} \quad \frac{di}{dt} = -\frac{E}{L} \quad (2.27)$$

So, the current fall. We note that the rise and fall of the current (i.e. the current ripple) is inversely proportional to the inductance, but is independent of the mean dc current, i.e. the ripple does not depend on the load. The current waveforms shown in Figure, the upper waveform corresponds to full load, i.e. the average current I_{dc} produces the full rated torque of the motor. If now the load torque on the motor shaft is reduced to half rated torque, and assuming that the resistance is negligible, the steady-state speed will remain the same but the new mean steady-state current will be halved, as shown by the lower dotted curve.

The average current I_{dc} further depends on the armature resistance that is

$$I_{dc} = \frac{\delta V - E}{R_a} \quad (2.28)$$

Now, the steady state speed of the motor is given by

$$\omega_m = \frac{\delta V}{K} - \frac{R_a}{K^2} T_a \quad (2.29)$$

Torque-speed characteristics

When the armature current is continuous the speed falls only slightly with load, because the mean armature voltage remains constant. But when the armature current is discontinuous (which is most likely at high speeds and light load) the speed falls off rapidly when the load increases, because the mean armature voltage falls as the load increases. Discontinuous current can be avoided by adding an inductor in series with the armature, or by raising the chopping frequency, but when closed-loop speed control is employed, the undesirable effects of discontinuous current are masked by the control loop.

Separately excited DC motor:

The torque-speed characteristics are drooping in nature as like in phase control. However, the drop in speed is less for chopper control than for phase control because of the nature of the supply voltage, which does not change with time. The region of discontinuous motor current operation can be reduced with chopper control by increasing the chopping frequency or introducing more inductance in motor circuit.

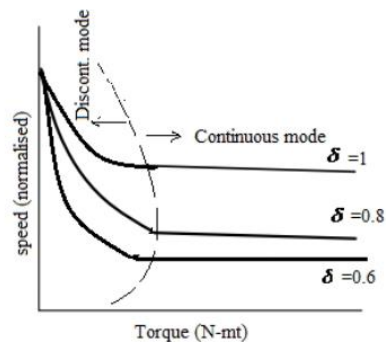

Regenerative braking (chopper drive)

Function

$$V_{dc} = 0, CH2 \text{ on}$$

$$V_{dc} = V, CH2 \text{ off } D_2 \text{ on}$$

The torque-speed curve is on second quadrant plane. So, regenerative braking takes place in second quadrant.

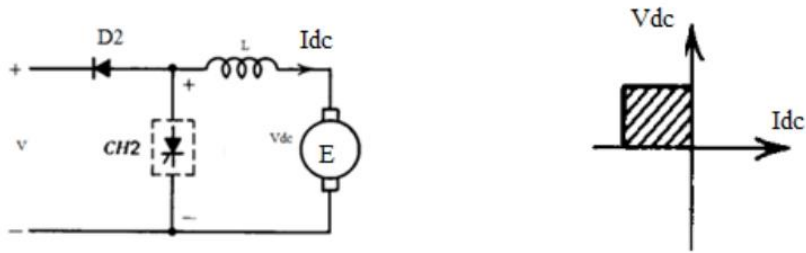

During turn on, the average voltage $V_{dc} = 0$ but, the current rises exponentially in motor circuit. During off, the average voltage $V_{dc} = \delta V$ and the current falls exponentially. The average current for this operation is

$$I_{dc} = \frac{E - \delta V}{R_a} \quad (2.30)$$

Since the torque is reversed, the torque is negative but the voltage polarity does not change.

$$T_b = -K I_{dc} \quad (2.31)$$

And speed is

$$\omega_m = \frac{\delta V}{K} - \frac{R_a}{K^2} T_a \quad (2.32)$$

Torque-speed characteristics for motoring and regenerative braking

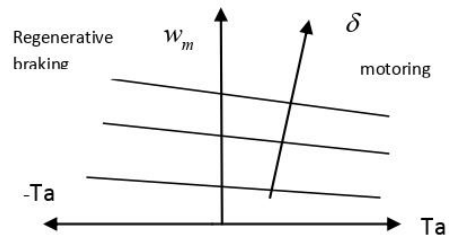

However, **both motoring and regenerative braking** can be brought into single chopper structure (two quadrant Type-A chopper or type-B chopper)

Type-A chopper

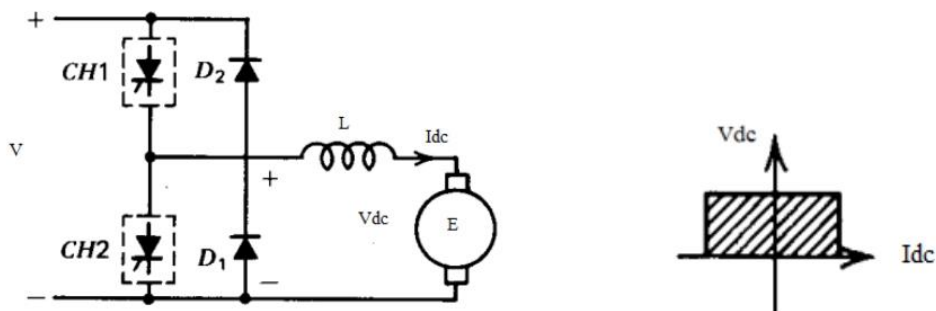

Function:

$V_{dc} = V$, CH1 or D_2 on
 $= 0$, CH2 or D_1 on $I_{dc} = \text{positive}$
 CH1 or D_1 on
 $= \text{negative}$
 CH2 or D_2 on

Type-B (two quadrant chopper)

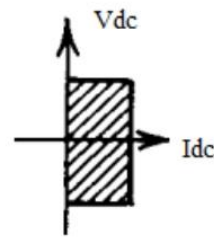
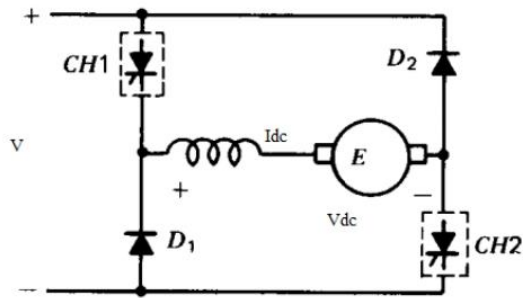

Function

$V_{dc} = +V$, CH1 and CH2 on

$V_{dc} = -V$, CH1 and CH2 off

D_1 and D_2 on

$V_{dc} = -V$, CH1

Fourth quadrant operation of Chopper fed Dc drive

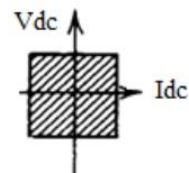
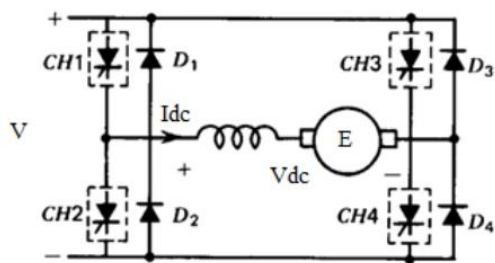

Function

$V_{dc} = \text{positive}$

$I_{dc} = \text{reversible}$

CH4 on and CH3 off

CH1 and CH2 operated

$V_{dc} = \text{negative}$

$I_{dc} = \text{reversible}$

CH2 on and CH1 off
 CH3 and CH4 operated

Dynamic braking (chopper drive)

During dynamic braking, the supply is taken away and the braking resistance R_b is connected across the supply terminal. Now, before the supply is disconnected the switch (chopper) is made on. The stored kinetic energy is made to pass through the switch, and the motor parameters. Then the braking resistance is connected and the switch is made open. So, the energy is made to pass through the diode and braking resistance. The current is flown in reverse direction and the braking torque is developed.

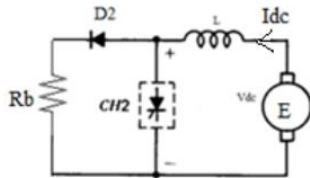

The energy consumed by the braking resistance of chopper is $E_b = I_{dc}^2 R_b (T - T_{on})$ (2.33)

Average power consumed by $P = \frac{E_b}{T} = I_{dc}^2 R_b (1 - \delta)$ (2.34)

Effective value of braking resistance is $R_b = \frac{P}{I_{dc}^2} = R_b (1 - \delta)$ (2.35)

Phase controlled converter for speed control

There are a number of controlled rectifier circuits, some fed from a 1-phase supply and others from a 3-phase supply. For the motor control, controlled rectifier circuits are classified as fully-controlled and half-controlled rectifiers. Single-phase controlled rectifiers are employed up to a rating of 10 kW and in some special cases up to 50 kW. For higher power ratings 3-phase controlled rectifiers are employed. As explained later in this chapter, the performance of a drive is improved when the rectifier pulse number is increased. Six-pulse operation is realized by employing the three-phase fully-controlled bridge rectifier. Twelve-pulse operation can also be obtained by connecting two six-pulse bridge controlled rectifiers.

Single-phase fully controlled rectifier (Two quadrant operation)

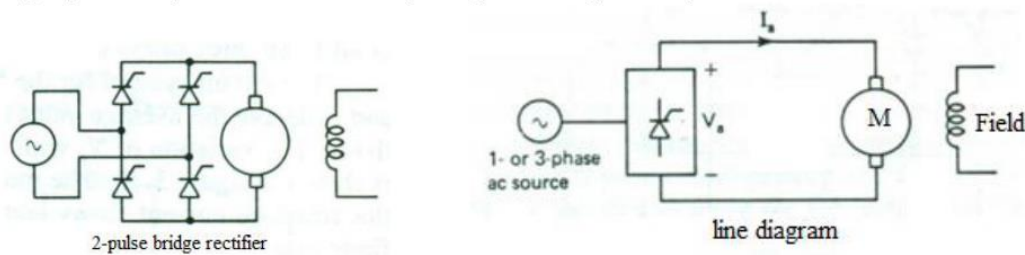

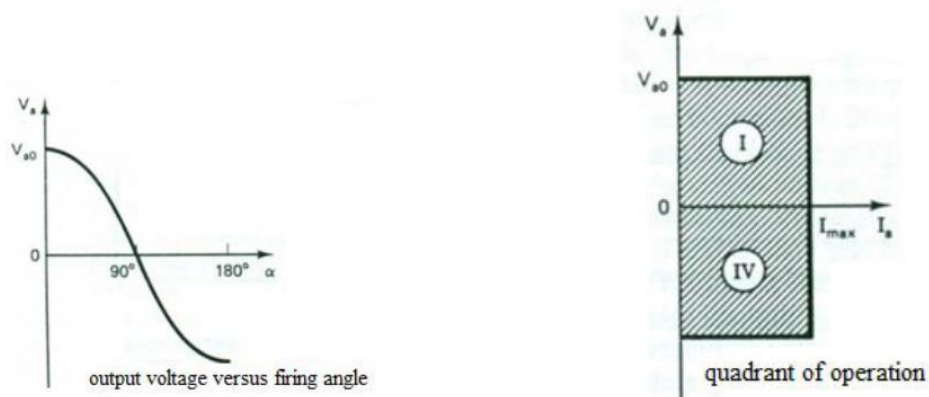

Let the output average voltage from the controlled ac-to dc converter is V_a and average current is I_a respectively. The variation of V_a with the firing angle α , assuming continuous conduction, is shown in figure. The motor is said to operate in continuous conduction when the armature current flows continuously - that is, it does not become zero for a finite time interval. The output voltage can be controlled from a full-positive ($+V_{a0}$) to a full negative ($-V_{a0}$) by controlling the firing angle from 0° to 180° . Since the output voltage can be controlled in either direction, the fully-controlled rectifiers are two-quadrant converters, providing operation in the first and fourth quadrants of the $V_a - I_a$ plane as shown. I_{max} is the rated rectifier current. With a negative output voltage, the rectifier works as a line-commutated inverter and the power flows from the load to the ac source.

Four quadrant operation (Closed-loop control)

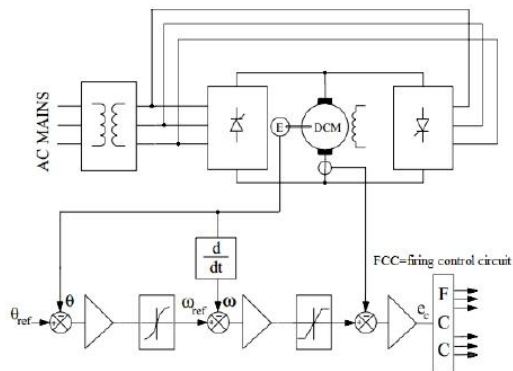

Bidirectional speed and position control system with a back-to-back (dual) thyristor converter.

A high-performance dc drive for a rolling mill drive may consist of such converter circuits connected for bi-directional operation of the drive. The interfacing of the firing control circuit to other motion-control loops, such as speed and position controllers, for the desired motion is also indicated. Two fully-controlled bridge ac-dc converter circuits are used back-to-back from the same ac supply. One is for forward and the other is for reverse driving of the motor. Since each is a two-quadrant converter, either

may be used for regenerative braking of the motor. For this mode of operation, the braking converter, which operates in inversion mode, sinks the motor current aided by the back emf of the motor. The energy of the overhauling motor now returns to the ac source. It may be noted that the braking converter may be used to maintain the braking current at the maximum allowable level right down to zero speed. A complete acceleration–deceleration cycle of such a drive is indicated in Fig. During braking, the firing angle is maintained at an appropriate value at all times so that controlled and predictable deceleration takes place at all times. The innermost control loop indicated in Figure is for torque, which translates to an armature current loop for a dc drive. Speed- and position-control loops are usually designed as hierarchical control loops. Operation of each loop is sufficiently decoupled from the other so that each stage can be designed in isolation and operated with its special limiting features.

Braking operation (separately excited dc motor)

A fully-controlled rectifier-fed dc separately excited motor is shown in figure. The polarities of output voltage, back emf, and armature current shown are for the motoring operation in the forward direction. The rectifier output voltage is positive and the firing angle is $0^\circ \leq \alpha \leq 90^\circ$. The motor can be made to work under regenerative braking if the armature current can reverse. This is not possible because the rectifier can carry current only in one direction. The only alternative available for the reversal of the flow of power is to reverse both the rectifier output voltage V_a and the motor back emf E with respect to the rectifier terminals and make $E > V$

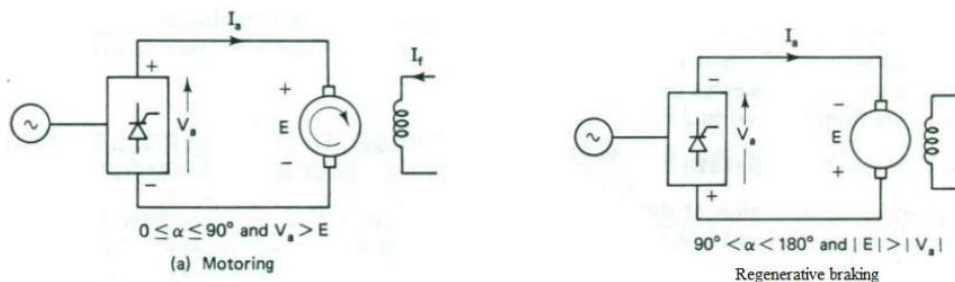

The reversal of the motor emf with respect to the rectifier terminals can be done by any of the following changes:

1. An active load coupled to the motor shaft may drive it in the reverse direction. This gives reverse regeneration (that is, operation in quadrant IV of the speed-torque plane). In this case no changes are required in the armature connection with respect to the rectifier terminals.
2. The field current may be reversed, with the motor running in the forward direction. This gives forward regeneration. In this case also no changes are required in the armature connection.
3. The motor armature connections may be reversed with respect to the rectifier output terminals, with the motor still running in the forward direction. This will give forward regeneration.

Steady-State Motor Performance Equations (continuous conduction)

For the purpose of analysis, the following assumptions are made:

1. Thyristors are ideal switches—that is, they have no voltage drop when conducting and no leakage current when blocking. The main implication of this assumption is that the rectifier voltage drop and losses are neglected. This assumption should not be used with low-voltage motors.

2. The armature resistance and inductance are constant. The skin effect, which is present due to a ripple in the motor current, does alter the value of the resistance.
3. During a given steady-state operation, the motor speed is constant. The motor torque does fluctuate due to the ripple in the motor current. Because the mechanical time constant is very large compared to the period of current ripple, the fluctuation in speed is in fact negligible. At constant speed, one can assume the back emf E is an ideal direct voltage for a given steady-state operation.
4. Source inductance is negligible.

The rectifier output voltage consists of one or two of the following intervals:

1. Duty Interval
2. During this interval

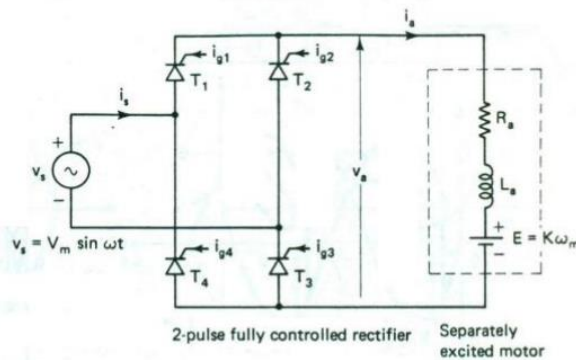

Duty Interval. When T1 and T3 conduct

$$v_a = L_a \frac{di_a}{dt} + R_a i_a + K\omega_m = V_m \sin \omega t \quad (2.36)$$

When T2 and T4 conduct

$$v_a = L_a \frac{di_a}{dt} + R_a i_a + K\omega_m = -V_m \sin \omega t \quad (2.37)$$

Zero current Interval:

$$i_a = 0 \quad \text{and} \quad v_a = K\omega_m \quad (2.38)$$

The average voltage can be found considering the any one pair of switches during the duty interval

Average motor terminal voltage V_a = average voltage drop across R_a + average voltage drop across L_a + back emf

$$\text{Now } V_a = \frac{1}{\pi} \int_{\alpha}^{\pi+\alpha} V_m \sin \omega t d(\omega t) = \frac{2V_m}{\pi} \cos \alpha = V_{a0} \cos \alpha \quad (2.39)$$

$$\text{Where } V_{a0} = \frac{2V_m}{\pi}$$

From the motor equation

$$V_a = I_a R_a + K\omega_m \quad (\text{average voltage across } L_a \text{ is zero}) \quad (2.40)$$

$$I_a = \frac{V_a - Kw_m}{R_a} = \frac{\left(\frac{2V_m}{\pi} \cos \alpha\right) - Kw_m}{R_a} \quad (2.41)$$

Comparing eq. (2.39), (2.40) and (2.41)

$$w_m = \frac{2V_m}{\pi K} \cos \alpha - \frac{R_a}{K_2} T_a \quad (2.42)$$

Speed-Torque Characteristics

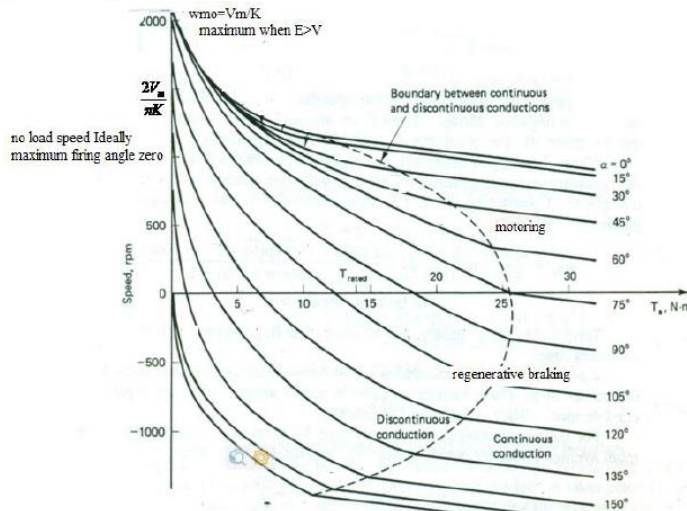

For torques less than the rated value, a low-power drive operates predominantly in the discontinuous conduction. In continuous conduction, the speed-torque characteristics are parallel straight lines, whose slope, according to equation (2.42), depends on the armature circuit resistance R_a . The effect of discontinuous conduction is to make the speed regulation poor. In continuous conduction, for a given α , any increase in load causes E and W_m to drop so that I_a and T_a can increase. The average terminal voltage V_a remains constant. On the other hand, in discontinuous conduction, any increase in load, and the accompanied increase in I_a causes β to increase. Consequently V_a reduces, and the speed drops by a larger amount than in the case of continuous conduction. Other disadvantages of discontinuous conduction are the nonlinear transfer characteristics of the converter and the slower transient response of the drive.

Stability:

Stability of the closed-loop system can be checked by examining the frequency response of the open-loop system, the gain being adjusted to ensure (by means of design criteria known as gain and phase margins) that, when the loop is closed for the first time, there is no danger of instability. This is that if the d.c. loop gain is too high, some closed-loop systems exhibit self-sustaining oscillations. When a system behaves in this way it is said to be unstable, and clearly the consequences can be extremely serious, particularly if large mechanical elements are involved. Also unstable behavior is characteristic of linear systems of third or higher order. Whenever the closed-loop system has an inherently oscillatory transient response,

increasing the proportional gain and/or introducing integral control generally makes matters worse that is the output response may become larger and settling time is more. So, the dc gain should be within its limit.

MODULE-3

ELRCTIC TRACTION

Traction system can be classified into non-electric and electric traction. Non-electric traction does not use electric at any stage. For ex. (steam engine drive and internal combustion drive). However, the electric drive system has certain advantages over other systems. So, electric drive system is widely used in rail traction.

Advantages:

- Due to cleanliness and pollution free, it can be used in underground railways.
- Starting torque is high, speed control is simple, braking is simple and efficient. By regenerative braking can be pumped back into the supply and saving the electric energy
- Less maintenance than steam locomotive.
- Put into service immediately
- The coefficient of adhesion is high
- Center of gravity is lower than steam locomotive. Hence it runs faster at curved routes.
- Saving high grade of coal and diesel

Disadvantages:

- High capital cost in erecting overhead supply
- Power failure for few minutes can cause dislocation of traffic for hours
- Communication lines gets interference

System of electric traction:

- DC system
- Single phase low frequency ac system
- Single phase high frequency ac system
- Three phase system
- Composite system

At present composite system is used for power supply. Composite systems are two types i) Kando system (single phase to three phase system) ii) Single phase to dc system

Kando System: This is the single phase, 25 KV, 50 hz supply that is converted to three phase at low frequency ($\frac{1}{2}$ to 10 hz) by the converter inside the locomotive. The three phase induction motor is used at low frequency due to the following advantages.

- Draws less current
- Improves the efficiency
- Speed control is easy

Advantages and disadvantages of 25KV, 50Hz supply

Advantages:

- Due to high voltage supply, the line current is less which will reduce the cross section of the conductor and makes the supporting structure light.
- Saving of substations
- Track is the return conductor
- Coefficient of adhesion is high

Disadvantages:

- Single phase ac system traction produces both voltage and current unbalance. So special care are to be taken
- Current unbalance produces heating in the alternator
- Voltage unbalance produces heating on induction motor
- Gives interference to the communication line
- Produces harmonics

Types of traction:

Three types of services for the passenger are available in rail traction.

- Urban service (Local train, the distance between stations <10 km)
- Suburban service (2.5 to 3.5 km)
- Main line service (intercity train and goods train, >10 km)

Goods train service also are three types:

- Main line freight service
- Local freight service
- Shunting service

In India, locomotives are classified according to their track gauge, motive power, the work they are suited for and their power or model number. The class name includes this information about the locomotive. It comprises 4 or 5 letters. The first letter denotes the track gauge. The second letter denotes their motive power (Diesel or Electric) and the third letter denotes the kind of traffic for which they are suited (goods, passenger, mixed or shunting). The fourth letter used to denote locomotives chronological model number.

The classification syntaxes

The first letter (gauge)

- W – Indian broad gauge (the "W" Stands for Wide Gauge - 5 ft 6 in)
- Y – meter gauge (the "Y" stands for Yard Gauge - 3 ft or 1000mm)
- Z – narrow gauge (2 ft 6 in)

The second letter (motive power)

- D – diesel
- C – DC electric (can run under DC overhead line only)
- A – AC electric (can run under AC overhead line only)
- CA – both DC and AC (can run under both AC and DC overhead line); 'CA' is considered a single letter
- B – Battery electric locomotive (rare)

The third letter (job)

- G – goods
- P – passenger
- M – mixed; both goods and passenger
- S – shunting (also known as switching engines or switchers in the USA and some other countries)
- U – electric multiple unit (used to carry commuters in city suburbs)
- R – Railcars

For example, in "WDM 3A":

"W"- broad gauge, "D"- diesel, "M"- suitable for both passenger and goods train, "3A"- locomotive power is 3,100hp (3-stands for 3000hp, A-stands for 100hp more)

Speed –Time curve for train movement:

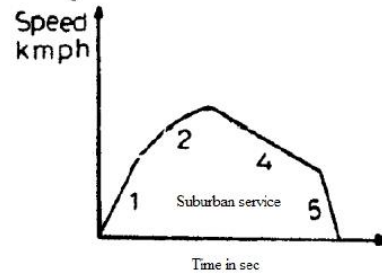
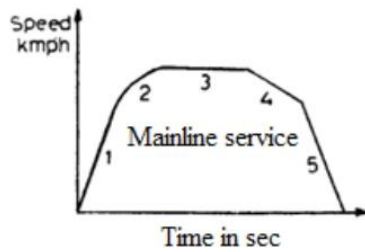

1. Acceleration with constant current (notching period called constant torque region)
2. Acceleration with constant voltage (constant power region)
3. Free running period (speed constant)
4. Coasting period (running with power cut off)
5. Braking period (retardation)

Distance and speed calculation fro curve:

The simplified version of curve is drawn for main line service for calculation of speed and time

Trapezoidal speed-time curve

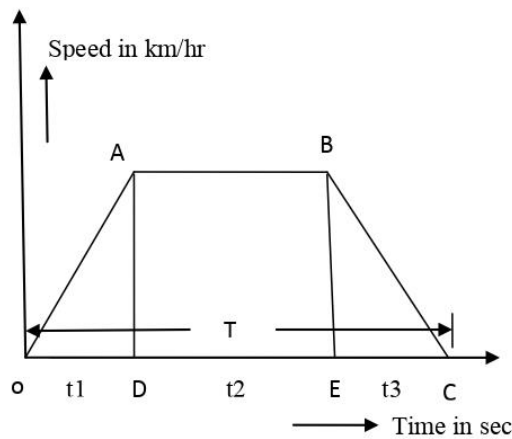

D = Distance in km between two stations

T = running time between two stations in sec

α = acceleration in kmphsec

β =retardation in kmphsec

N_m =maximum speed in kmph

N_a = average speed in kmph

$$t_1 = \frac{N_m}{\alpha} = \text{time of acceleration}$$

$$t_3 = \frac{N_m}{\beta} = \text{time of retardation}$$

The total distance can be formulated from the above curve that

$$D = \frac{N_m}{3600} (T - N_m k) \quad \text{in km} \quad (3.1)$$

$$\text{Where } k = \frac{\alpha + \beta}{2\alpha\beta}$$

For urban and sub urban duties the quadrilateral speed-time curve can be done.

quadrilateral speed-time curve

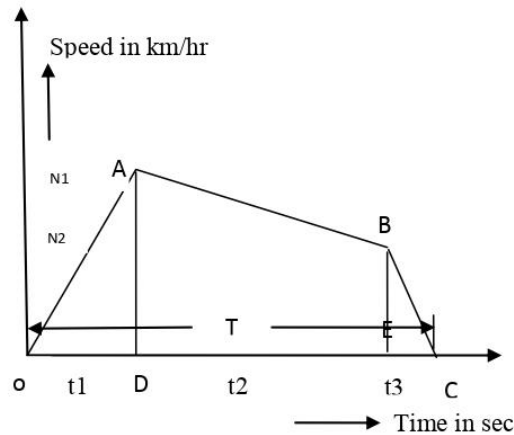

β_c = coasting retardation in kmphsec

β = retardation in kmphsec

$$t_2 = \frac{N_1 - N_2}{\beta_c} \quad \text{coasting time in sec}$$

$$t_1 = \frac{N_1}{\alpha} \quad \text{acceleration time in sec}$$

$$D = \frac{1}{7200} [T(N_1 + N_2) - N_1 N_2 \left(\frac{1}{\alpha} + \frac{1}{\beta} \right)] \quad \text{in km} \quad (3.2)$$

Average speed and scheduled speed:

The average speed of a train is defined as the ratio of the distance between the consecutive stations to the time taken by the train to travel the distance.

Scheduled speed: The scheduled speed is defined as the distance between two consecutive stations to the actual time of run and time for stop. So, scheduled speed is always less than the average speed.

HEATING AND COOLING

The size and power rating of the motor depends upon

- the heating effect
- loading condition and classes of duty
- Environmental condition

Insufficient power rating, either fails to drive or damages and shut down due to overloading of the motor and power modulator. However, induction and synchronous motor operates at a low power factor when operating below rated power.

When the motor operates heat is produced due to losses (copper, iron and friction) inside the machine and its temperature rises. The heat produced during no load is from iron parts to winding and when loaded heat is flows from winding to surrounding as more heat is seen on winding than winding. The temperature reaches at a steady state when the heat generated becomes equal to heat dissipated into the surrounding medium. This steady temperature depends on power loss, which in turn depends on the output power of the machine. Since the temperature has direct relation with output power, it is termed as thermal loading of the machine.

An electric machine is designed for a given temperature rise is decided by its insulation. The various insulations are Y,A,E,B,F,H,C and the corresponding temperature sustainable are 90° , 105° , 120° , 130° , 155° , 180° and above 180° .

Thermal Modeling

It is very difficult to have the thermal modeling of the machine due to its heterogeneous material. During the no load heat is more in iron parts and it flows to the winding and during overload heat flows from winding to the surrounding. So, there is uniform of temperature gradient. For accurate thermal modeling the following assumptions are made.

- The machine is considered to be homogeneous
- Heat dissipation is proportional to the different of temperature between the body and the surrounding
- The rate of heat dissipation is constant.

Heating Curve:

Heat balance equation shows

Heat generated=heat dissipated to the surrounding + heat stored in the body

That is
$$Wdt = A\lambda\theta dt + Gsd\theta \quad (4.1)$$

Where W = power loss on the motor responsible for heat in time (dt) in watt

G = weight of the acyive parts of the motor in kg

s = specific heat of the material of the body in J/degree/kg

A =cooling surface in mt^2

λ = sp. Heat dissipation or emissivity in $J/s/mt^3/degree$

θ = temp. rise of the body (degree)

$d\theta$ = temp. rise due (dt)

When the temp. reaches a constant value the body is said to be reached a maximum value (θ_m). The change in temperature $d\theta = 0$

So there is no store of heat in the body.

The heat generated (Wdt = heat dissipated $A\lambda\theta dt$)

Now

$$Wdt = A\lambda\theta_m dt \quad (4.2)$$

$$\Rightarrow W = A\lambda\theta_m$$

$$\theta_m = \frac{W}{A\lambda} \quad (\text{maximum temp. rise}) \quad (4.3)$$

Eq. (4.1) can be re arranged as $Wdt - A\lambda\theta dt = Gsd\theta$

$$(W - A\lambda\theta)dt = Gsd\theta$$

$$\frac{d\theta}{dt} = \frac{W}{Gs} - \frac{A\lambda}{Gs}\theta \quad (4.4)$$

If cooling medium is absent, then no dissipation takes place. So, eq (4.1) is reduced to

$$Wdt = Gsd\theta \quad (4.5)$$

Which gives linear relationship between θ and t .

Therefore,
$$\frac{\theta}{t} = \frac{W}{Gs} \quad (4.6)$$

If τ_1 is the time taken to reach θ_m , then

$$\frac{\theta_m}{\tau_1} = \frac{W}{Gs} \quad (4.7)$$

Substituting $\theta_m = \frac{W}{A\lambda}$ in eq (4.7) we have, $\tau_1 = \frac{Gs}{A\lambda}$ (4.8)

Where τ_1 is the thermal (heating) time constant.

Further eq (4.1) can be arranged to find the time during temperature rise as

$$Wdt = A\lambda\theta dt + Gsd\theta$$

$$Wdt - A\lambda\theta dt = Gsd\theta$$

$$dt = \frac{Gsd\theta}{W - A\lambda\theta} \quad \text{Integrating both sides}$$

$$\int dt = \left(\int \frac{Gsd\theta}{W - A\lambda\theta} \right)$$

$$\Rightarrow t = -\frac{Gs}{A\lambda} (\log(W - A\lambda\theta) - \log K) \quad (4.9)$$

Log K is constant to be found out at initial conditions

Eq. (4.9) can be written as $\log\left(\frac{W - A\lambda\theta}{K}\right) = -t\left(\frac{A\lambda}{Gs}\right)$

$$\Rightarrow \frac{W - A\lambda\theta}{K} = e^{-\left(\frac{A\lambda}{Gs}\right)t} \quad (4.10)$$

At $t=0$, $\theta = 0$ so, $K = W$

$$\text{From eq.(4.10) } \theta = \theta_m \left(1 - e^{-\frac{t}{\tau}}\right) \quad (4.11)$$

Where, $\tau = \frac{Gs}{A\lambda}$ and $\theta_m = \frac{W}{A\lambda}$

But in many cases the initial temperature is not zero. And hence at $t=0$, $\theta = \theta_0$. So, eq. (4.10) reduces to

$$\frac{W - A\lambda\theta}{W - A\lambda\theta_0} = e^{-\frac{t}{\tau}} \text{ which reduces } \theta = \theta_m \left(1 - e^{-\frac{t}{\tau}}\right) + \theta_0 e^{-\frac{t}{\tau}} \quad (4.12)$$

Cooling Curve:

When the machine is switched off from the supply or when the load is reduced, the machine cools. For first case, the machine cools to the ambient temperature.

Case-1

$$0 = A\lambda\theta dt + Gsd\theta$$

$$\Rightarrow dt = -\frac{Gsd\theta}{A\lambda\theta} \text{ integrating both sides } \Rightarrow t = -\frac{Gs}{A\lambda} (\log W - \log K_1)$$

$$\Rightarrow \theta = K_1 e^{-\frac{t}{\tau_2}} \text{ where } \tau_2 = \frac{Gs}{A\lambda} \text{ (cooling time constant)}$$

When $t=0$, $\theta = \theta_m$, $K_1 = \theta_m$

$$\text{So, } \theta = \theta_m e^{-\frac{t}{\tau_2}} \quad (4.13)$$

Case-2

When the load is reduced, let the temperature cools off from θ_f , so, $\theta_f = \frac{W_1}{A\lambda}$ where W_1 is the total loss at reduced load, then

$$\theta = \theta_m \left(1 - e^{-\frac{t}{\tau_2}}\right) + \theta_f e^{-\frac{t}{\tau_2}} \quad (4.14)$$

For forced cooled $\tau_1 = \tau_2$

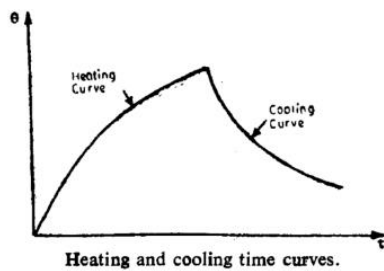

Drives for Specific Applications

Steel Mill:

The major function of rolling of steel mill is to reduce the cross section of the metal while increasing the length proportionally. Steel mill usually produce blooms, slabs, rails, sheets, strips, beams, bar and angles.

Technologically steel mill is divided into four categories :

- Continuous cold rolling mills
- Reversing cold rolling mills
- Continuous hot rolling mills
- Reversing hot rolling mills

In reversing mill there is only one stand carrying the rolls that press the metal and metal is passed through this stand alternately forward and backward several times in order to reduce it to desired size. Each motion or travel is known as pass. A continuous mill consists of several stands, each one of them carrying pressing rolls. The metal passes through all the stands in only one direction and gets rolled.

Drives used in steel mills:

Dc motors is usually used in both reversible and continuous mills. Motor for reversing mills must have high starting torque, wide speed range, precise speed control, be able to withstand overload and pull out torque. Acceleration from zero to base speed and then to top speed and subsequent reversal from top speed backward to top speed forward must be achieved in few second. The moment of inertia of armature must be as small as possible and motors are enclosed and force ventilated. Ward-Leonard method for speed control is used. However, the speed control is replaced by thyristorised converter.

Paper Mills:

Pulp making and paper making are the two main important job for paper mills. The drive required each of them is quite different.

Pulp Making:

Pulp making requires grinding machines which almost run at constant speed that is acquired by synchronous motor. Motors run at speed of 200-300 rpm. However, pulp by mechanical means ,the motor runs at speed of 2000-3000 rpm for large grinder. Pulp is made by cutting the logs into several pieces and treated with alkalies and grass, rags etc. During the chemical treatment the material is continually beaten by the beater. Beater requires speed less than 200 rpm so, slip ring induction motor is used. The end product of the beater is passed to chipping and refining .so, synchronous motor is used.

Paper making:

The machine that makes the paper from pulp has to perform several jobs from five sections. i) Couch section(Wire section) ii) Press section iii) Dryer section iv) Calender section v) Reel section

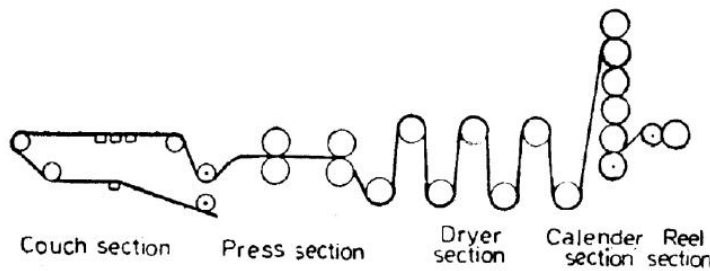

Drive Requirement:

- Speed should be adjustable over a range of as large as 10:1
- In the wet end of paper machine the speed section should be independently adjustable.
- In the last two sections, speed control circuit must be good enough for tension control
- Control system employed should be flexible in nature.

Textile Mills:

From the raw material to finishing of cloths the mill has to perform several processes such as cotton to slivers, spinning, weaving and finishing.

Cotton to slivers: The process by which the seeds are separated from cotton is called ginning. The cottons are converted into slivers and then processed by drawing machine. The slivers are then made lap form.

Spinning: In this process, the slivers are made yarn is made of sufficient strength. This yarn is wound on bobbins by winding machine.

Weaving: The yarn is made in uniform layers. Weaving consists of two sets of threads, one which extends throughout the length of the fabric and other whose thread go across. This process is done in a loom.

Finishing: This consists a number of processes such as bleaching, dyeing, printing, calendaring, stamping and packing. The impurities like oil and grease are removed and the fabric is made white by bleaching.

Drives used in different sections:

In loom process loom motor is used where frequent start and stop is required. These results high temperature rise and sufficient ventilation is required. High torque three phase squirrel cage induction motor is used in loom motor. The motor is totally enclosed and must have capacity to absorb the moisture content during the process.

Card motor: It is similar to loom motor but it runs continuously for card drum.

Spinning motor: For good quality of spinning the acceleration must be smooth. Three types of drives are required here, single speed motor (4 or 6 pole squirrel cage induction motor), two speed motor (4/6 or 8/6 pole motor) and two motor drive (two separate motor for driving single pulley)

Microprocessor Based drive:

Advantages:

- The complexity of the system is reduced
- The software supported control using micro-processors performs the function of controllers, feedback, decision making of the drive system
- The hardware implementation in thyristorised controller unit four-quadrant operation using dual converter, vector control can be realized with software programs on micro-processor with least possible hardware
- Digital control has an inherent improved noise immunity

- The control is free from drift and parameter variation due to temperature

Limitations:

- Due to communication between the microprocessor and the analog circuitry done by A/D and D/A converter, there are sampling and quantizing error
- The response in micro-processor is slow in comparison with dedicated hardware
- The development of software may be costly and time consuming

Closed loop dc drive microprocessor based speed control

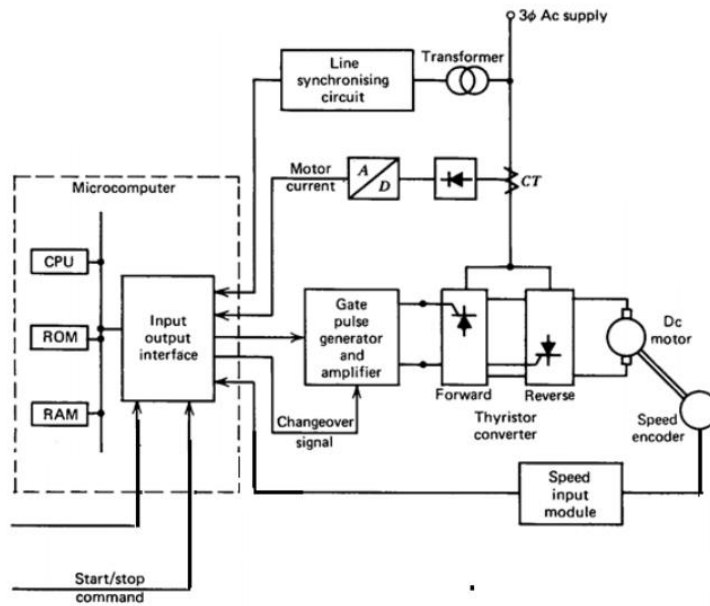

Block diagram of a reversing dc drive using microcomputer control system.